



FIXTURE



PROTECT



POWER

Ingenuity Applied

Welcome to Boston Group

**We** listen carefully,  
look beyond the challenge and  
come up with smart solutions,  
exploring new domains every  
day together with you. This is  
who we are and what we do.

We call it ingenuity applied.

— **Russell Rubin, CEO**

# At the very beginning

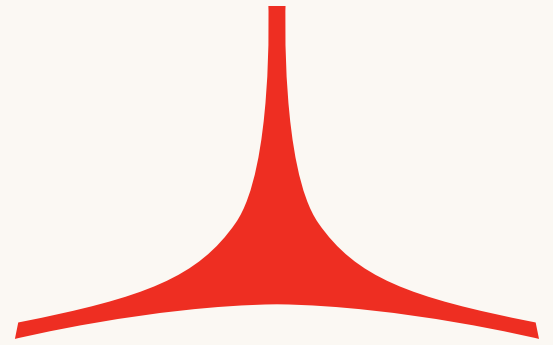

**It all started in the US during the Great Depression in a neighborhood full of immigrants from all over the world where they began a new life and formed new friendships. Just like our founder Irv Rubin, who became part of a group of close friends, calling themselves the triple-three. They grew up together and helped each other out whenever they could.**

In 1937, one of Irv's friends had a local store and needed a better method to handle, prepare and present food and non-food items. So Irv, with the input from his friend, designed, developed and manufactured special fixtures out of metal that met the needs of his friends shop: Boston Metal Products was born.

## Simple Yet Smart

Soon after, Irv founded our first factory in East Boston in 1937, just as the self-service supermarkets were introduced. We stood at the very beginning of this retail revolution. In the 1960s Irv's son Richard joined Boston Metal Products and grew the company nationally with innovative solutions.

One day, when Richard was unloading an order of fixtures, the retailer cautioned him to avoid hitting the walls and expensive refrigeration equipment in the store. Richard then had an idea: asset protection. The Boston Bumper was created. He was the first in the world to come up with this simple yet smart solution.

## Ingenuity Applied

This type of innovative spirit still drives us today. We love to listen to our customers and come up with smart solutions. With our in-house design and state-of-the-art production facilities we can prototype and produce just what you need down to the last detail, whether it's in power, protection or fixtures.

Over the last 80 years we have grown from a regional manufacturer to an international group providing smart solutions to the global retail industry and beyond. All the while our entrepreneurial spirit continues to drive us towards new domains. Irv and Richard applied ingenuity back then. Just like we do today.

**We**  
cherish our  
heritage and at  
the same time  
love to explore  
new domains



# The way we work

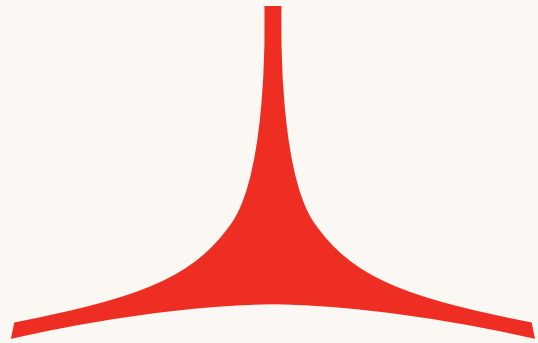

**Since 1937 we have helped retail and other institutional clients create service environments designed to fit their needs. We continuously read our customers and keep coming up with smart solutions. Whether it was our first bumper, our power track or our modular power system for self check out cash points.**

There is no one-size-fits-all solution, which is why we work with every client individually to ensure specification, design and manufacture results are achieved. It means that we can focus all of our capabilities on designing and building the best system to serve you.

## Smart from the Heart

Our philosophy is simple: we work smart from the heart. We collaborate with every single client by carefully listening to their needs, speaking their language, asking the right questions and gaining insight from their perspective. We have a restless energy, coming up with ideas and always seeking new challenges and possibilities. This way we cut to the core of our clients' needs. And then: we build exactly that - your need - made possible by our own metal and plastic manufacturing facilities.

## Superior Products

Having our own metal and plastic manufacturing facilities allows us to maintain strict quality controls, adhere to all international standards and deliver a superior product.

In our global manufacturing center of excellence in Ravenna, Ohio, metal, wire and electrical components are designed and manufactured. With an automated production line, a fully staffed tool and die department, and UL-rated electrical assembly, we produce the highest quality products. Coupled with an extensive array of color and powder coating capabilities and you'll understand why we're able to meet virtually any custom design challenge.

In Ohio, we also offer 9 fully automated plastic extruders, 2 injection molding machines, plus in-house tool and die design and development. Whether you're looking for S-shapes, U-shapes or waves, our experienced team can make your idea a reality. In addition, we offer extensive co-extrusion and dual extrusion capabilities. Colors match beautifully because we use only the highest quality resins and polymers. Once your color is calibrated in our system, you can expect consistent, vibrant color matching every time.

## Global Coverage

We offer global coverage 24/7 and work compliant to all international safety, mechanical, electrical and environmental standards.

## Our Team

We are engineers, designers, manufacturers, account managers plus a customer service team - all working as one. For each client we assign a cross-functional team to deliver true value. Give us your toughest problem and we will come up with a solution that meets your needs and budget.

Our team speaks your language. We are culturally mixed, multilingual and understand what you are saying, even between the lines. For almost a century we've been around the block and know our way around.



# Services we provide

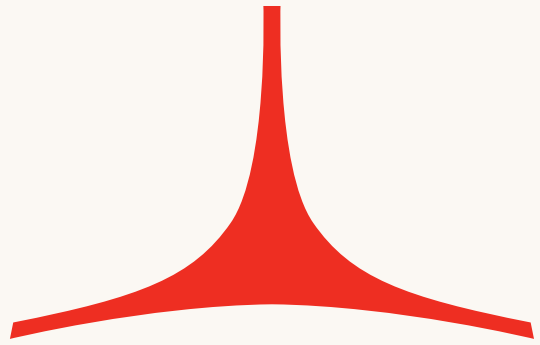

## Design & Prototype

**See your imagination come to life**

See your imagination come to life before anything is built. Our advanced simulation software allows you to view your design in isolation or within a larger environment, in any color or finish from any angle. Want to get an actual feel of your design? We can prototype anything with our meticulous metal and plastic machinery, which can produce 1 to 100.000.000 high precision products. This makes any product development accurate, fast and more efficient.

## Manufacturing

**Have it cut, bent and painted**

Whatever is designed can be made to your specifications required. After all, an idea is only as good as it's ability to function. This is achieved by our cutting edge capabilities in manufacturing metal, plastic and wood. Whether the material needs to be punched, bent, laser cut, powder coated or injection molded, our fully automated cells operate 24/7 to get the job done. And whether you need 1 or 100.000 products, from A to Z we can reduce lead times.

Meanwhile, all our services, products and factories comply to all international safety, mechanical, electrical and environmental standards. This way you can be sure we will have your design delivered safe and sound in no-time.

## Integrated Solutions

**Expect added value to your store**

This is where it all comes together. Whether you're opening, maintaining or remodeling your store-environment, we can help you do it quicker, better and more efficient. With integrated solutions we bundle our expertise in design, manufacturing and logistics and turn it into value added turn-key systems. We are your one-stop provider of unique services and products that integrate seamlessly into any environment and will exceed your expectations.

## Global Coverage

**Connect with us anytime, anywhere**

Our reach is far and wide. With offices and distribution centers in the US, Europe, Asia and Australia, we've got you covered. This way we can reduce lead times, so you can have your design supplied and delivered within no-time. Meanwhile, we will get you all the support you need. We speak your language, ask the right questions and gain insight from your perspective. This way we cut to the core of your needs.



# Ingenuity applied

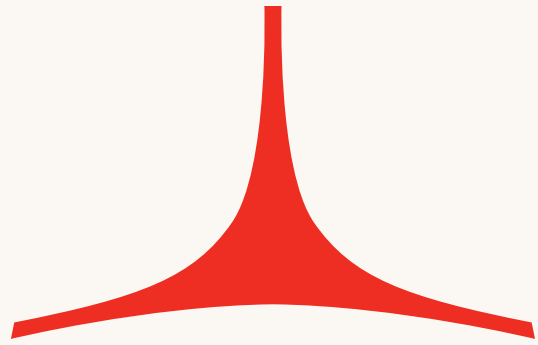

**Boston Group provides total solutions to energize environments, protect assets and support unique shopping or working experience. From initial concept to full product rollout we expertly guide the process to deliver the right solutions for your needs.**

Since 1937 we have helped our clients create retail and work environments designed to fit their needs. Our smart solutions employ our vast design skills and manufacturing capabilities - providing creative products that protect assets, supplying innovative power solutions and developing custom fixtures that address your unique needs.

## Our Markets:

- **Food and Non-Food Retail**
- **Pharmacy**
- **Convenience Store**
- **Warehouse & Distribution Centers**
- **Hardware Store**
- **Lighting Showrooms**
- **Door & Window**
- **Refrigeration OEM**

At Boston Group our team delivers true value. Give us your toughest problem and we will come up with a solution that meets your needs and budget. There is no one-size-fits-all solution, which is why we work with every client individually to ensure specification, design and manufacture results are achieved. We focus all of our capabilities on designing and building the best system to serve you.

From our design centers and production facilities in the US and Europe, we come up with smart ideas and create high-quality products. Having our own metal and plastic manufacturing facilities allows us to maintain strict quality controls, adhere to all international standards and deliver a superior product.

## Our Process:

### Assessment & Survey

Our customer centric team of engineers, customer service and account managers will take the time to meet with you and survey your environment to understand what type of asset protection, power or fixture need is required.

### Planning

Once our survey is complete we provide you with a detailed proposal for your project depending on your operational and environmental needs with layouts, BOM and a deployment plan.

### State-of-the-Art Manufacturing

An idea is only as good as its ability to function. That is where our specialized manufacturing engineers come in. They ensure whatever is designed can be made to the specifications required. This is achieved by our cutting edge metal, wood fabrication, plastic extrusion and injection molding capabilities.

### Deployment & Installation

Our expert customer service and logistics team will deploy your items when and where you need them. Boston Group's experienced staff of engineers and product management are with you every step of the way to supervise and support a seamless installation.

### Certification & Compliance

Every product we make adheres to strict third party national safety standards for mechanical, electrical and environmental compliance.

Boston Group cares about the environment. With over 10 years of being a UL Environment Certified company (the only bumper manufacturer with this certification), we are proud to have placed great emphasis on incorporating recycled material in our product design and manufacture. We are pleased we can report a 15% increase in our year over year usage of post consumer, post industrial content.

# It's all in the details

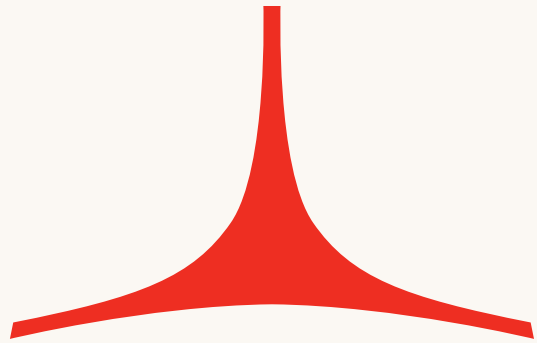

**Let our design, engineering and manufacturing experts help invigorate your environment**

Boston Group, founded in 1937, offers the very latest in design and manufacturing to turn your projects around quickly from concept to finished solutions.

## Integrated Solutions Philosophy

Boston Group designs and manufactures fixtures that bundle a variety of core materials (metal, wood, plastic, power, lighting and technology) into a modular design that allows seamless integration into any environment. Ingenuity Applied!

### **Cutting edge capabilities**

To stay competitive, Boston Group continuously invests in its manufacturing capabilities to provide value driven solutions, quickly and efficiently.

### **Insight and thoughtfulness**

Our people make it all happen. To make a project viable, we formulate cross-functional teams comprising of account managers, designers, purchasers manufacturing engineers and customers service support.

### **Experience with energy**

The philosophy of Boston Group is to generate true value for our customers. We take time to understand your goals and objectives and apply our extensive experience to create configurable and scalable solutions for your environment.

## Challenge us...

At Boston Group, we love a good challenge. We strive to learn and push boundaries, so give us your toughest problem and we'll come up with a solution that meets your needs and budget.



These are our

# Markets

M 1

Food and Non-Food Retail

M 2

Pharmacy

M 3

Convenience Store

M 4

Warehouse & Distribution Centers

M 5

Hardware Store

M 6

Lighting Showrooms

M 7

Door & Window

M 8

Refrigeration OEM



# ELEVATE Your Retail Store Experience with Our Comprehensive Solutions

The combination of customer satisfaction, security, customization, durability, compliance, efficiency, along with our expertise and partnership, are an essential part of enhancing the operational success of retail food and non-food store chains.



POWER



PROTECT



FIXTURE



Boston Group

**Corporate Headquarters** 3 Highwood West, Suite 100, Tewksbury, MA 01876 Tel. 781-395-7417 — 800-225-1633 (toll-free) — [sales.us@boston-group.com](mailto:sales.us@boston-group.com)

**European Headquarters** Sydneystraat 15, Rotterdam, 3047 BP, Netherlands Tel. +31 10 238 14 00 — [sales.emea@boston-group.com](mailto:sales.emea@boston-group.com) [www.boston-group.com](http://www.boston-group.com)

MADE IN THE USA • V SEPT 2025



# PROTECT



## Bumpers & Asset Protection

### EcoFlex, EcoSuperFlex & EcoRigid

For over 85 years Boston Group has set the standard with its full line of floor and wall mounted bumpers, and crash rails for retailers. With over a decade of being a UL Environment Certified company (the only bumper manufacturer with this certification), we are proud to have placed great emphasis on incorporating recycled material in our product design and manufacture.

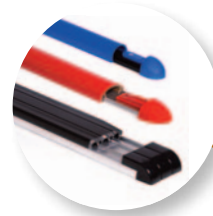

- Maximize Customer Satisfaction
- Enhance Security and Reduce Loss
- Versatile and Customizable Solutions
- Durable and Cost-Effective
- Compliant and Reliable
- Expert Support and Partnership

## EdgeTrim

### Recyclable Flexible Display Trim

EdgeTrim is cost-effective and provides tough impact protection for your fixtures and display cases. It installs easily with double-sided tape, dual-lock replaceable fasteners or adhesive cement.



## Guidance & Security Railing System

### Stainless Steel

These railings help guide customers, prevent accidents, and create a secure atmosphere. They serve to clearly mark entrances, exits, paths, and cart areas to help customers navigate the store safely.



## EcoBase

### EcoRigid® Cove Base & Flexible Flat Base

Boston EcoBase offers a variety of cost-effective base molding options that will protect and enhance your walls.



## POWER

## PROTECT

## FIXTURE

## Round, Square or X-Frame Bollards

Extreme Storefront Protection for safeguarding customers and property from accidental or deliberate vehicle impacts. Can be powder coated or covered with Stainless Steel or colored plastic bollard covers. CRASH TEST RATING: ASTM F3016 S20  
\*Certified to stop a 5000lb vehicle traveling at 20mph



Change the appearance by adding a round cover to your bollard. Popular Cover Options - More Options Available Upon Request



Boston Group

Corporate Headquarters 3 Highwood West, Suite 100, Tewksbury, MA 01876 Tel. 781-395-7417 — 800-225-1633 (toll-free) — sales.us@boston-group.com

European Headquarters Sydneystraat 15, Rotterdam, 3047 BP, Netherlands Tel. +31 10 238 14 00 — sales.emea@boston-group.com. [www.boston-group.com](http://www.boston-group.com)

**Back of House**

**These products provide extreme protection for your back room and vestibule.**  
 Bollards, Corner Guards, Box Rail, and Warehouse Rack Guards

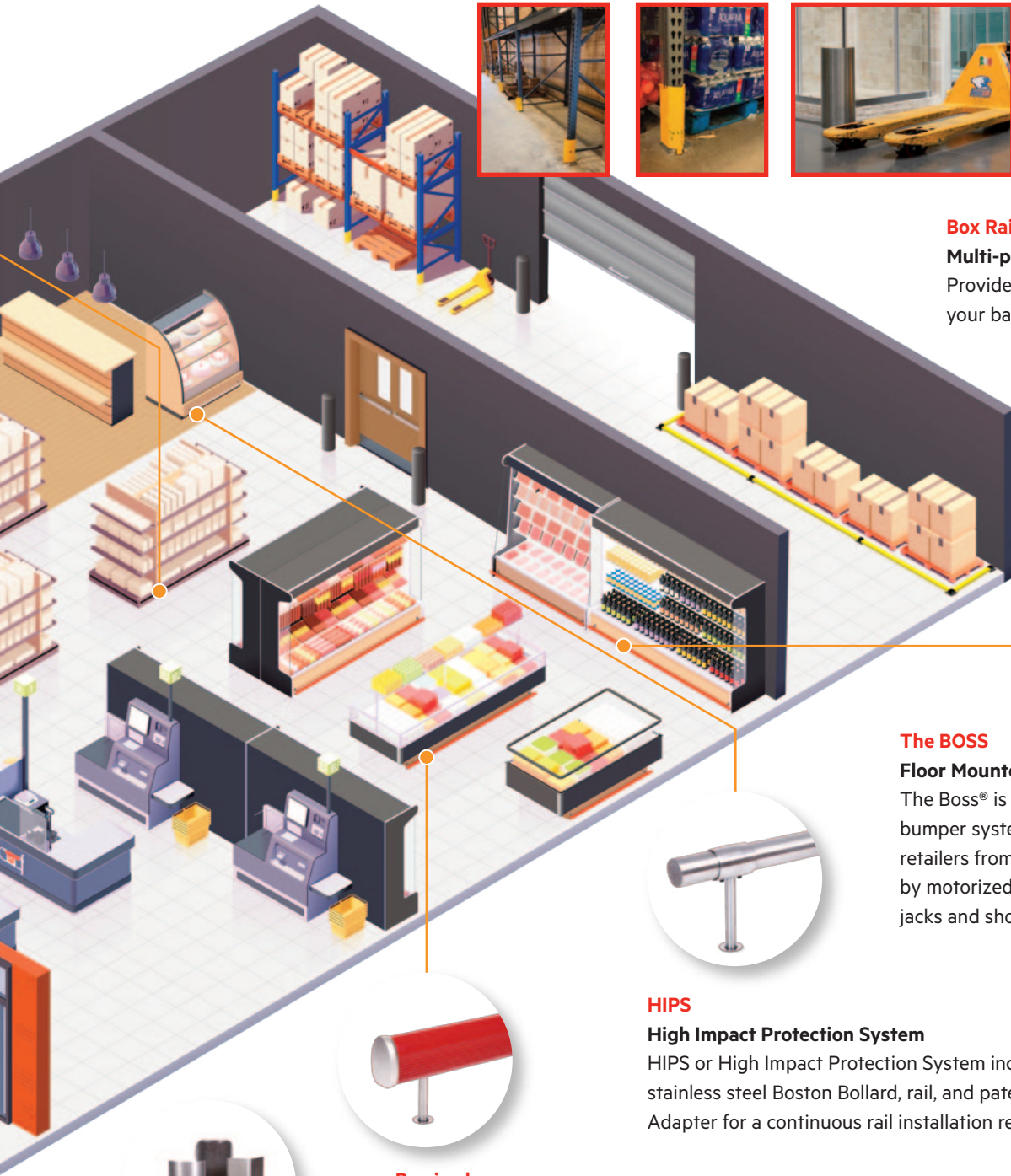

**Box Rail**

**Multi-purpose Fence Rail Guard**  
 Provides extreme protection for your back room and vestibule.



**The BOSS**

**Floor Mounted Bumper System**

The Boss® is a floor-mounted bumper system that protects retailers from costly damage caused by motorized floor scrubbers, pallet jacks and shopping carts.



**HIPS**

**High Impact Protection System**

HIPS or High Impact Protection System includes a 10-gauge stainless steel Boston Bollard, rail, and patented 90° Corner Adapter for a continuous rail installation requiring no end caps.



**Barricade**

**Heavy Duty Floor Mounted Bumper**

The simple unique design allows for less component parts, easier assembly and installation with maximum protection.



**EcoGuards**

**Stainless Steel Floor Mounted Corner Guards and Warehouse Racking Protectors**

Boston manufactures a complete line of 10-gauge, brush-finished stainless steel and CRS corner guards that can withstand impact up to 4,000 lbs!





# FIXTURE

## Point of Service (POS), Counters, and Fixtures

Boston Group's line of fixture and cabinet solutions for store environments offers durable modules that easily adapt to meet your needs. These fixtures can incorporate plug & play power and lighting elements to deliver fast and seamless integration. Unlimited and customized merchandising options are available.

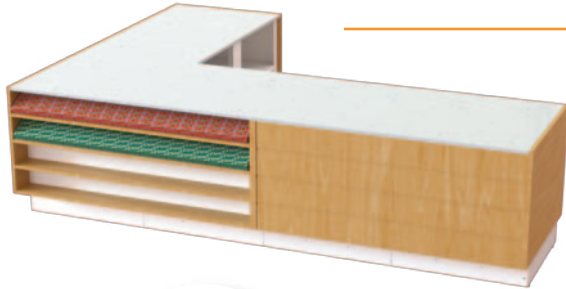

### Gondola Doors: Single and Multiple Bays

#### Enhanced Security

- Deters theft, vandalism, and unauthorized access.
- Protects valuable merchandise and store assets.
- Can be tailored to fit specific sizes and aesthetic requirements.

#### Robust Construction

- Made from durable and sustainable materials; steel, aluminum, and plexiglass.
- Optional multi-point locking systems for added security.



POWER



PROTECT



FIXTURE

Boston Group

Corporate Headquarters 3 Highwood West, Suite 100, Tewksbury, MA 01876 Tel. 781-395-7417 — 800-225-1633 (toll-free) — sales.us@boston-group.com

European Headquarters Sydneystraat 15, Rotterdam, 3047 BP, Netherlands Tel. +31 10 238 14 00 — sales.emea@boston-group.com. [www.boston-group.com](http://www.boston-group.com)

# Leaders in Loss Prevention Solutions

ELEVATE

## Lockable Storage

Boston Group Security Systems for retailers provide several features and benefits that enhance safety, deter crime, and protect assets.



Lockable Cabinet with Adjustable Shelves

- Maximize Customer Satisfaction
- Enhance Security and Reduce Loss
- Versatile and Customizable Solutions
- Durable and Cost-Effective
- Compliant and Reliable
- Expert Support and Partnership



## Exterior Security Cages

- Ideal for protecting merchandise, product totes, propane tanks and more.
- 1" SQR 16GA Tubular Frame Construction
- Powder coated to resist corrosion.
- Tamper resistant hardware to minimize theft.
- Expanded Metal for maximum visibility but providing security.
- Easily assembled with connection hardware accessible on interior.



**Corporate Headquarters** 3 Highwood West, Suite 100, Tewksbury, MA 01876 Tel. 781-395-7417 — 800-225-1633 (toll-free) — [sales.us@boston-group.com](mailto:sales.us@boston-group.com)

**European Headquarters** Sydneystraat 15, Rotterdam, 3047 BP, Netherlands Tel. +31 10 238 14 00 — [sales.emea@boston-group.com](mailto:sales.emea@boston-group.com) [www.boston-group.com](http://www.boston-group.com)



# POWER

FASTLANE® Total Store  
'Plug&Play' System

### FASTLANE® Total Store 'Plug&Play' System

Boston's FastLane® modular wiring solutions are cost-effective 'Plug & Play' wiring methods that carry power and voice/data from electrical and computer patch panels to your selling floor.

Our FastLane® wiring solutions are custom designed and configured to meet your specific needs while still allowing for a 100% functional, pre-tested modular installation. The system arrives 'as-designed' to eliminate hard wiring and 'on-the-fly design' common with traditional methods. Save installation time and labor costs with quick, reliable connections from the switch gear to point-of-use.

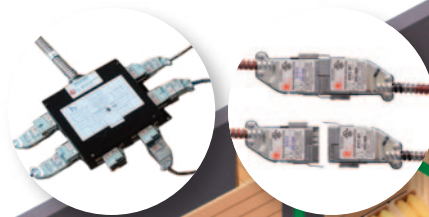

POWER



PROTECT



FIXTURE

**Our total end to end solution of product and service provides power to all areas of a store: lighting, refrigeration, POS, Service areas. Currently installed in thousands of retail locations across US, Canada and Mexico.**

Boston Group

**Corporate Headquarters** 3 Highwood West, Suite 100, Tewksbury, MA 01876 Tel. 781-395-7417 — 800-225-1633 (toll-free) — sales.us@boston-group.com

**European Headquarters** Sydneystraat 15, Rotterdam, 3047 BP, Netherlands Tel. +31 10 238 14 00 — sales.emea@boston-group.com. [www.boston-group.com](http://www.boston-group.com)

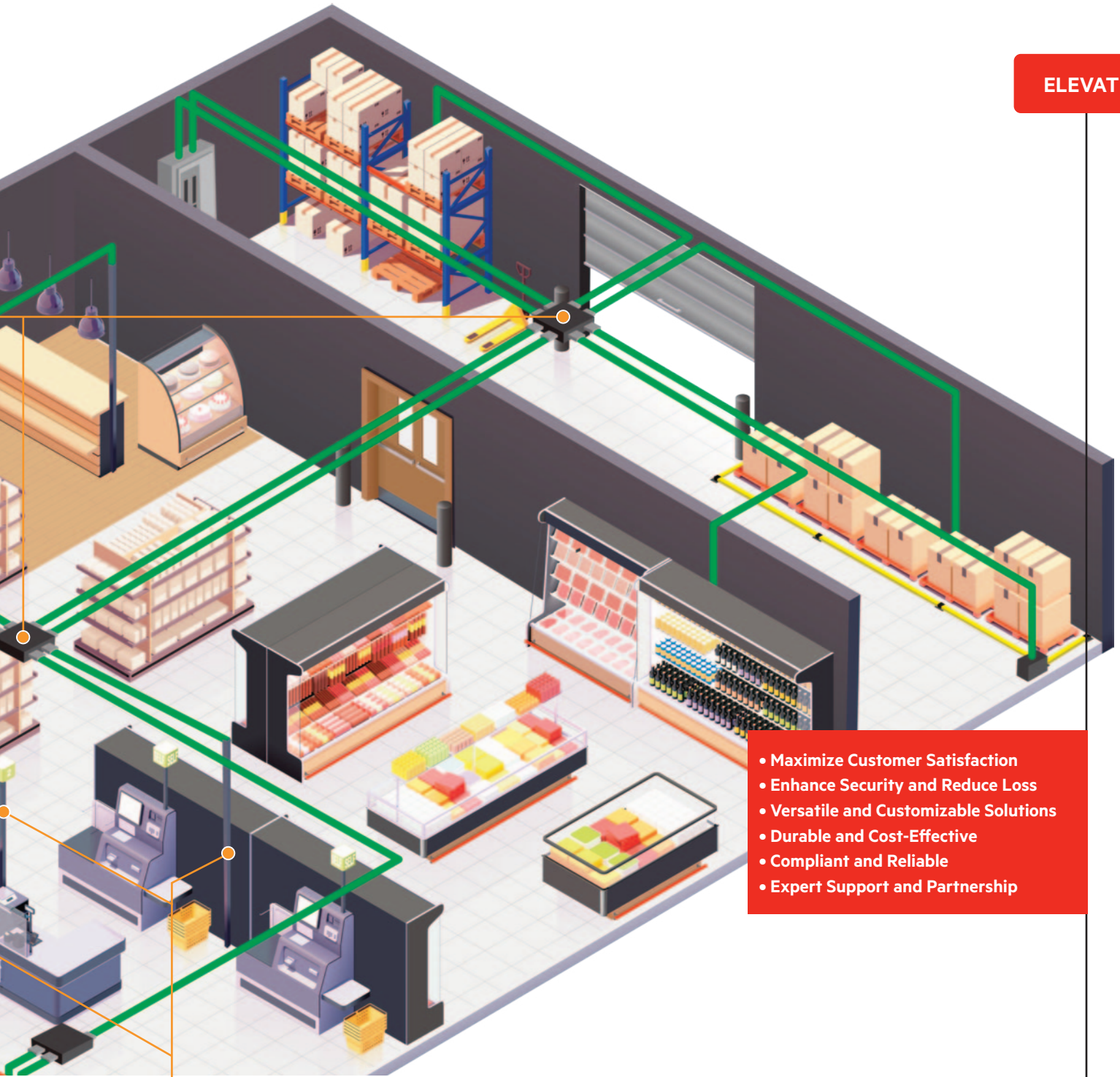

- Maximize Customer Satisfaction
- Enhance Security and Reduce Loss
- Versatile and Customizable Solutions
- Durable and Cost-Effective
- Compliant and Reliable
- Expert Support and Partnership

Power Poles



**Power Poles**

Boston Group offers a wide range of PowerPole product solutions that fulfill any power/voice and data distribution needs with UL compliant, reliable 'plug & play' connectors.





### Maximize Customer Satisfaction:

Our stylish and functional counters and checkout areas enhance the shopping experience, allowing for a seamless flow of customers. Well-designed fixtures reduce wait times and improve service efficiency, resulting in happier customers and increased loyalty.

### Enhance Security and Reduce Loss:

Our state-of-the-art asset protection and loss prevention products safeguard your inventory and mitigate theft. By implementing our solutions, convenience stores can significantly reduce shrinkage, leading to improved profit margins and protecting your bottom line.

### Versatile and Customizable Solutions:

Our fixtures are designed to adapt to the unique layout and branding of your stores. With customizable options, we ensure that your convenience store stands out while effectively utilizing space for optimal product visibility and sales.

### Durable and Cost-Effective:

Crafted from high-quality materials, our fixtures are built to last. Investing in our durable products means fewer replacements, lower maintenance costs, and greater long-term value for your stores.

### Compliant and Reliable:

Our solutions meet all industry standards for safety and functionality. By choosing our products, you can trust that you're equipping your stores with reliable solutions that comply with regulations and provide peace of mind.

### Expert Support and Partnership:

We don't just sell products; we build long-term partnerships. Our team offers expert advice, installation support, and ongoing service to ensure that your stores operate at their highest potential.



POWER



PROTECT



FIXTURE

Boston Group

**Corporate Headquarters** 3 Highwood West, Suite 100, Tewksbury, MA 01876 Tel. 781-395-7417 — 800-225-1633 (toll-free) — [sales.us@boston-group.com](mailto:sales.us@boston-group.com)

**European Headquarters** Sydneystraat 15, Rotterdam, 3047 BP, Netherlands Tel. +31 10 238 14 00 — [sales.emea@boston-group.com](mailto:sales.emea@boston-group.com) [www.boston-group.com](http://www.boston-group.com)



MADE IN THE USA • V SEPT 2025

# PHARMACY



M 2

## ELEVATE Your Pharmacy Experience with Our Comprehensive Solutions

Boston Group's fixture solutions bundle a variety of materials and components to create true value. Our unique Pharmacy Fixture System integrates metal, wood, plastic, power and lighting in a modular design format that fits seamlessly into any environment. Standard or custom, Boston Group has the ability to offer the right fixture to fill any need. That's Ingenuity Applied.



POWER



PROTECT



FIXTURE



Boston Group

Corporate Headquarters 3 Highwood West, Suite 100, Tewksbury, MA 01876 Tel. 781-395-7417 — 800-225-1633 (toll-free) — sales.us@boston-group.com

European Headquarters Sydneystraat 15, Rotterdam, 3047 BP, Netherlands Tel. +31 10 238 14 00 — sales.emea@boston-group.com [www.boston-group.com](http://www.boston-group.com)

MADE IN THE USA • V SEPT 2025

# Pharmacy Fixture Solutions

Design & Simulation | Production & Manufacturing

## Design & Simulation

With cutting edge design and manufacturing capabilities Boston Group stays ahead with continuous investment in capabilities to deliver value driven solutions. Our advanced simulation and modeling software allow you to view your fixture design in isolation, as single unit or within the intended environment.

## Production & Manufacturing

Boston Group employs fully automated manufacturing cells that punch, bend, form and laser-cut to exact specifications, bridging concept to product release.

## Certification & Compliance

We ensure every product we make complies with strict third party national safety standards for mechanical, electrical and environmental compliance.

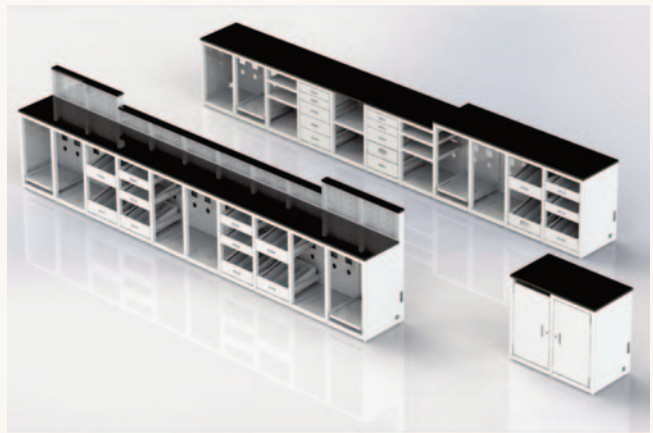

FIXTURE

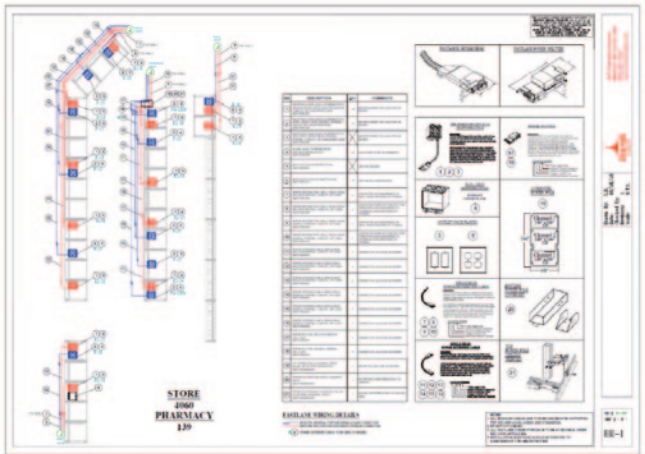
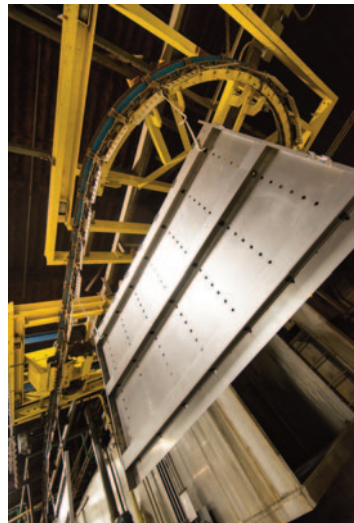

POWER



PROTECT



FIXTURE

Boston Group

**Corporate Headquarters** 3 Highwood West, Suite 100, Tewksbury, MA 01876 Tel. 781-395-7417 — 800-225-1633 (toll-free) — sales.us@boston-group.com

**European Headquarters** Sydneystraat 15, Rotterdam, 3047 BP, Netherlands Tel. +31 10 238 14 00 — sales.emea@boston-group.com. [www.boston-group.com](http://www.boston-group.com)

# Let our design, engineering and manufacturing experts help invigorate your environment

Boston Group, founded in 1937, offers the very latest in design and manufacturing to turn your projects around quickly from concept to finished solutions.

## Integrated Solutions Philosophy

Boston Group designs and manufactures fixtures that bundle a variety of core materials (metal, wood, plastic, power, lighting and technology) into a modular design allowing seamless integration into any environment. That's Ingenuity Applied!

## Cutting edge capabilities

To stay competitive, Boston Group continuously invests in its manufacturing capabilities to provide value driven solutions, quickly and efficiently.

## Insight and thoughtfulness

Our people make it all happen. To make a project viable, we utilize cross-functional teams comprising of account managers, designers, purchasers manufacturing engineers and customers service support.

## Experience with energy

The philosophy of Boston Group is to generate true value for our customers. We take time to understand your goals and objectives and apply our extensive experience to create configurable and scalable solutions for your environment.

## Challenge us...

At Boston Group, we love a good challenge. We strive to learn and push boundaries. So give us your toughest problem and we'll come up with a solution that meets your needs and budget.

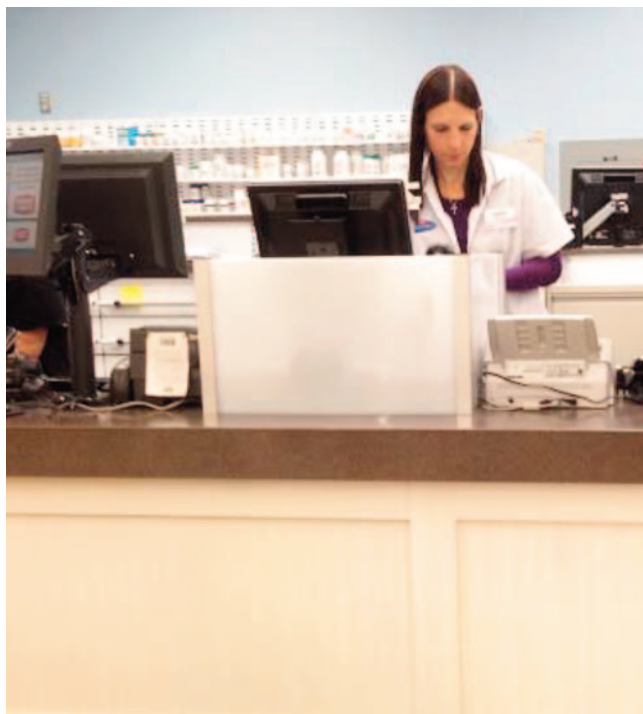



#### Maximize Customer Satisfaction:

Our stylish and functional counters and checkout areas enhance the shopping experience, allowing for a seamless flow of customers. Well-designed fixtures reduce wait times and improve service efficiency, resulting in happier customers and increased loyalty.

#### Enhance Security and Reduce Loss:

Our state-of-the-art asset protection and loss prevention products safeguard your inventory and mitigate theft. By implementing our solutions, convenience stores can significantly reduce shrinkage, leading to improved profit margins and protecting your bottom line.

#### Compliant and Reliable:

Our solutions meet all industry standards for safety and functionality. By choosing our products, you can trust that you're equipping your stores with reliable solutions that comply with regulations and provide peace of mind.

#### Versatile and Customizable Solutions:

Our fixtures are designed to adapt to the unique layout and branding of your stores. With customizable options, we ensure that your convenience store stands out while effectively utilizing space for optimal product visibility and sales.

#### Expert Support and Partnership:

We don't just sell products; we build long-term partnerships. Our team offers expert advice, installation support, and ongoing service to ensure that your stores operate at their highest potential.

#### Durable and Cost-Effective:

Crafted from high-quality materials, our fixtures are built to last. Investing in our durable products means fewer replacements, lower maintenance costs, and greater long-term value for your stores.



POWER



PROTECT



FIXTURE

Boston Group



**Corporate Headquarters** 3 Highwood West, Suite 100, Tewksbury, MA 01876 Tel. 781-395-7417 — 800-225-1633 (toll-free) — [sales.us@boston-group.com](mailto:sales.us@boston-group.com)

**European Headquarters** Sydneystraat 15, Rotterdam, 3047 BP, Netherlands Tel. +31 10 238 14 00 — [sales.emea@boston-group.com](mailto:sales.emea@boston-group.com) [www.boston-group.com](http://www.boston-group.com)



M 3

# ELEVATE Your Convenience Store Experience with Our Comprehensive Solutions

The combination of customer satisfaction, security, customization, durability, compliance, efficiency, along with our expertise and partnership, are an essential part of enhancing the operational success of convenience store chains.



POWER



PROTECT



FIXTURE



Boston Group

**Corporate Headquarters** 3 Highwood West, Suite 100, Tewksbury, MA 01876 Tel. 781-395-7417 — 800-225-1633 (toll-free) — [sales.us@boston-group.com](mailto:sales.us@boston-group.com)

**European Headquarters** Sydneystraat 15, Rotterdam, 3047 BP, Netherlands Tel. +31 10 238 14 00 — [sales.emea@boston-group.com](mailto:sales.emea@boston-group.com) [www.boston-group.com](http://www.boston-group.com)

MADE IN THE USA • V SEPT 2025



# PROTECT

## Bumpers & Asset Protection

For over 85 years Boston Group has set the standard with its full line of floor and wall mounted bumpers, and crash rails for retailers. With over a decade of being a UL Environment Certified company (the only bumper manufacturer with this certification), we are proud to have placed great emphasis on incorporating recycled material in our product design and manufacture.

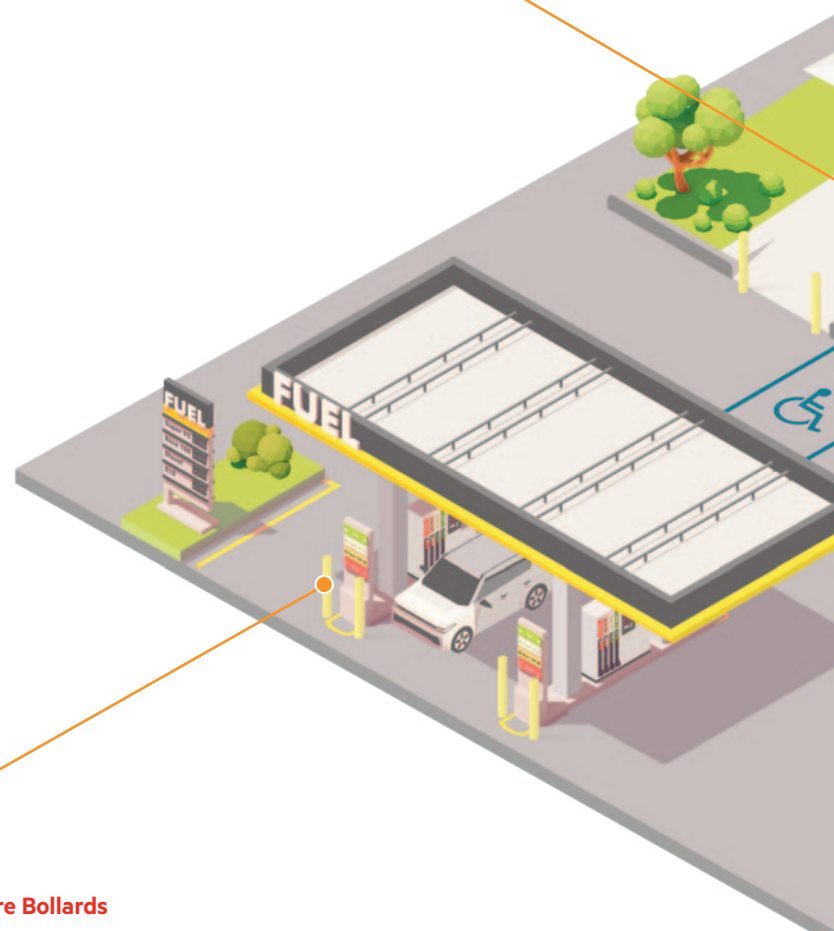



Sign Post Add-On  
(ADA Sign with Blue Cover)

## Round or Square Bollards

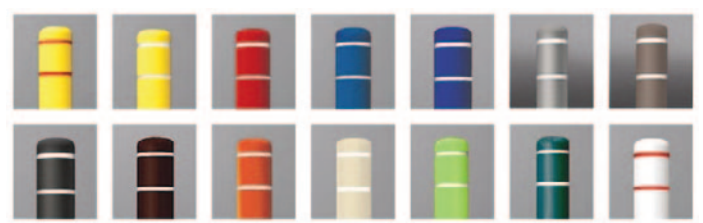
Extreme Storefront Protection for safeguarding customers and property from accidental or deliberate vehicle impacts. Can be powder coated or covered with Stainless Steel or colored plastic bollard covers. CRASH TEST RATING: ASTM F3016 S20 \* Certified to stop a 5000lb vehicle traveling at 20mph



Change the appearance by adding a round cover to your bollard.  
Popular Cover Options - More Options Available Upon Request

-  POWER
-  PROTECT
-  FIXTURE

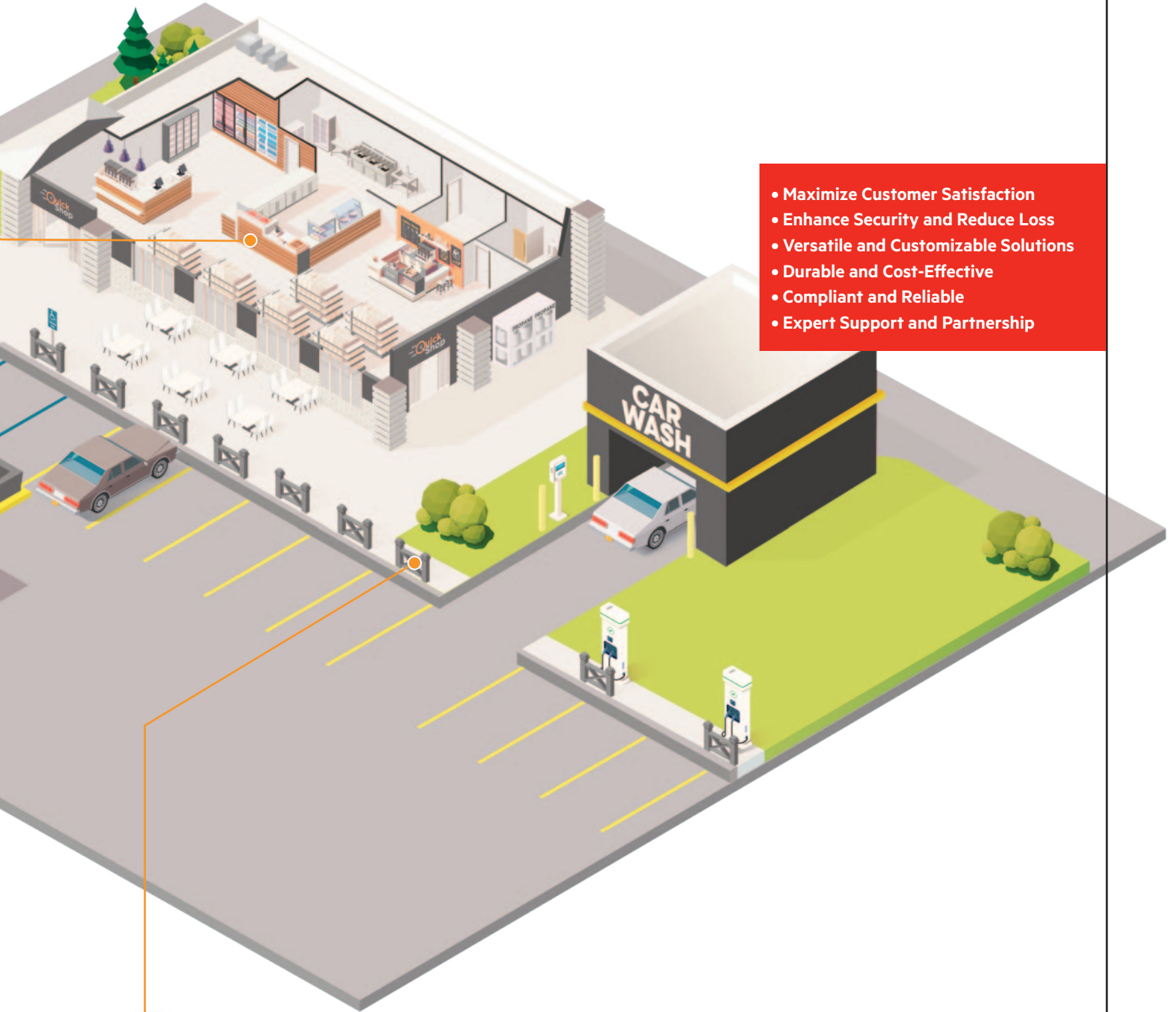

- Maximize Customer Satisfaction
- Enhance Security and Reduce Loss
- Versatile and Customizable Solutions
- Durable and Cost-Effective
- Compliant and Reliable
- Expert Support and Partnership



**X-Frame Bollards**

Extreme Storefront Protection for safeguarding customers and property from accidental or deliberate vehicle impacts.

CRASH TEST RATING: ASTM F3016 S20 \* Certified to stop a 5000lb vehicle traveling at 20mph





# FIXTURE

## Point of Service (POS), Counters, and Fixtures

Boston Group's line of fixture and cabinet solutions for store environments offers durable modules that easily adapt to meet your needs. These fixtures can incorporate plug & play power and lighting elements to deliver fast and seamless integration. Unlimited and customized merchandising options are available.

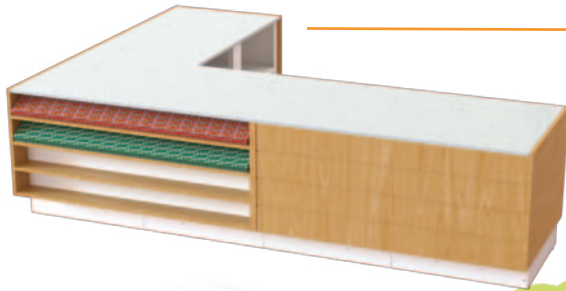

## Gondola Doors: Single and Multiple Bays

### Enhanced Security

- Deters theft, vandalism, and unauthorized access.
- Protects valuable merchandise and store assets.
- Can be tailored to fit specific sizes and aesthetic requirements.

### Robust Construction

- Made from durable and sustainable materials; steel, aluminum, and plexiglass.
- Optional multi-point locking systems for added security.



POWER



PROTECT



FIXTURE

Boston Group

**Corporate Headquarters** 3 Highwood West, Suite 100, Tewksbury, MA 01876 Tel. 781-395-7417 — 800-225-1633 (toll-free) — [sales.us@boston-group.com](mailto:sales.us@boston-group.com)

**European Headquarters** Sydneystraat 15, Rotterdam, 3047 BP, Netherlands Tel. +31 10 238 14 00 — [sales.emea@boston-group.com](mailto:sales.emea@boston-group.com) [www.boston-group.com](http://www.boston-group.com)

# Leaders in Loss Prevention Solutions

ELEVATE



## Lockable Storage

Boston Group Security Systems for retailers provide several features and benefits that enhance safety, deter crime, and protect assets.



Lockable Cabinet with Adjustable Shelves

- Maximize Customer Satisfaction
- Enhance Security and Reduce Loss
- Versatile and Customizable Solutions
- Durable and Cost-Effective
- Compliant and Reliable
- Expert Support and Partnership

## Exterior Security Cages

- Ideal for protecting merchandise, product totes, propane tanks and more.
- 1" SQR 16GA Tubular Frame Construction
- Powder coated to resist corrosion.
- Tamper resistant hardware to minimize theft.
- Expanded Metal for maximum visibility but providing security.
- Easily assembled with connection hardware accessible on interior.



**Corporate Headquarters** 3 Highwood West, Suite 100, Tewksbury, MA 01876 Tel. 781-395-7417 — 800-225-1633 (toll-free) — sales.us@boston-group.com

**European Headquarters** Sydneystraat 15, Rotterdam, 3047 BP, Netherlands Tel. +31 10 238 14 00 — sales.emea@boston-group.com. [www.boston-group.com](http://www.boston-group.com)

MADE IN THE USA • V SEPT 2025



# POWER

## FASTLANE® Total Store 'Plug&Play' System

Boston's FastLane® modular wiring solutions are cost-effective 'Plug & Play' wiring methods that carry power and voice/data from electrical and computer patch panels to your selling floor.

Our FastLane® wiring solutions are custom designed and configured to meet your specific needs while still allowing for a 100% functional, pre-tested modular installation. The system arrives 'as-designed' to eliminate hard wiring and 'on-the-fly design' common with traditional methods. Save installation time and labor costs with quick, reliable connections from the switch gear to point-of-use.



FASTLANE® Total Store  
'Plug&Play' System

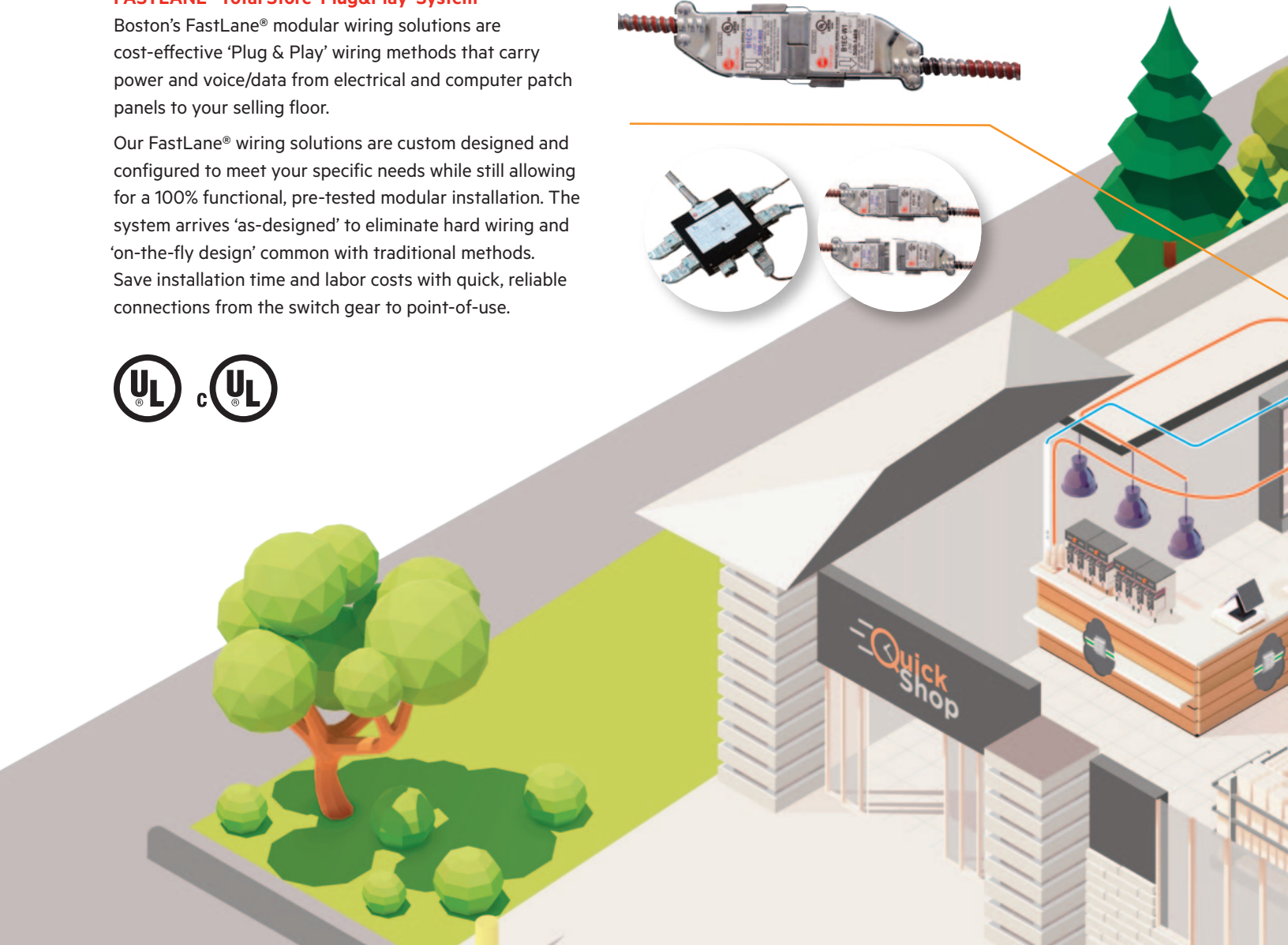
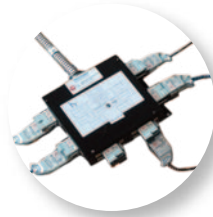

POWER



PROTECT



FIXTURE

**Our total end to end solution of product and service provides power to all areas of a store: lighting, refrigeration, POS, Service areas. Currently installed in thousands of retail locations across US, Canada and Mexico.**

Boston Group

**Corporate Headquarters** 3 Highwood West, Suite 100, Tewksbury, MA 01876 Tel. 781-395-7417 — 800-225-1633 (toll-free) — sales.us@boston-group.com

**European Headquarters** Sydneystraat 15, Rotterdam, 3047 BP, Netherlands Tel. +31 10 238 14 00 — sales.emea@boston-group.com. [www.boston-group.com](http://www.boston-group.com)



- Maximize Customer Satisfaction
- Enhance Security and Reduce Loss
- Versatile and Customizable Solutions
- Durable and Cost-Effective
- Compliant and Reliable
- Expert Support and Partnership

Power Poles



**Power Poles**

Boston Group offers a wide range of PowerPole product solutions that fulfill any power/voice and data distribution needs with UL compliant, reliable 'plug & play' connectors.





#### Maximize Customer Satisfaction:

Our stylish and functional counters and checkout areas enhance the shopping experience, allowing for a seamless flow of customers. Well-designed fixtures reduce wait times and improve service efficiency, resulting in happier customers and increased loyalty.

#### Enhance Security and Reduce Loss:

Our state-of-the-art asset protection and loss prevention products safeguard your inventory and mitigate theft. By implementing our solutions, convenience stores can significantly reduce shrinkage, leading to improved profit margins and protecting your bottom line.

#### Versatile and Customizable Solutions:

Our fixtures are designed to adapt to the unique layout and branding of your stores. With customizable options, we ensure that your convenience store stands out while effectively utilizing space for optimal product visibility and sales.

#### Durable and Cost-Effective:

Crafted from high-quality materials, our fixtures are built to last. Investing in our durable products means fewer replacements, lower maintenance costs, and greater long-term value for your stores.

#### Compliant and Reliable:

Our solutions meet all industry standards for safety and functionality. By choosing our products, you can trust that you're equipping your stores with reliable solutions that comply with regulations and provide peace of mind.

#### Expert Support and Partnership:

We don't just sell products; we build long-term partnerships. Our team offers expert advice, installation support, and ongoing service to ensure that your stores operate at their highest potential.



POWER



PROTECT



FIXTURE

Boston Group



**Corporate Headquarters** 3 Highwood West, Suite 100, Tewksbury, MA 01876 Tel. 781-395-7417 — 800-225-1633 (toll-free) — [sales.us@boston-group.com](mailto:sales.us@boston-group.com)

**European Headquarters** Sydneystraat 15, Rotterdam, 3047 BP, Netherlands Tel. +31 10 238 14 00 — [sales.emea@boston-group.com](mailto:sales.emea@boston-group.com) [www.boston-group.com](http://www.boston-group.com)

MADE IN THE USA • V SEPT 2025



M 4

# ELEVATE Your Warehouse + Distribution Centers Effectiveness

At Boston Group, we understand the dynamic needs of modern warehouse and distribution centers. Our comprehensive product portfolio is designed to enhance safety, efficiency, and adaptability in high-demand environments. Whether you're outfitting a new facility or upgrading an existing one, Boston Group delivers innovative solutions that work as hard as you do.



POWER



PROTECT



FIXTURE



Boston Group

**Corporate Headquarters** 3 Highwood West, Suite 100, Tewksbury, MA 01876 Tel. 781-395-7417 — 800-225-1633 (toll-free) — [sales.us@boston-group.com](mailto:sales.us@boston-group.com)

**European Headquarters** Sydneystraat 15, Rotterdam, 3047 BP, Netherlands Tel. +31 10 238 14 00 — [sales.emea@boston-group.com](mailto:sales.emea@boston-group.com) — [www.boston-group.com](http://www.boston-group.com)

MADE IN THE USA • V SEPT 2025



# PROTECT

## Asset Protection & Safety

Protect your infrastructure and personnel with our robust safety solutions:

- **EcoFlex, EcoRigid, EcoSuperFlex Bumpers**  
Flexible and impact-resistant options for wall and fixture protection.
- **Corner Guards & Bollards**  
Stainless steel and high-impact polymer guards to shield vulnerable areas.

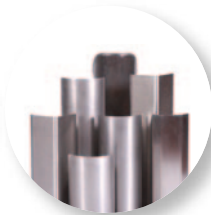
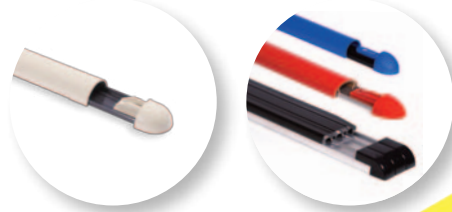

## Dock Door Protectors

Are fork lifts damaging the loading dock doors?

Our dock door protectors safeguard both the door panels when in the down position as well as the door tracks in the up position.

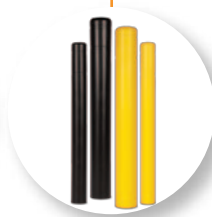

POWER



PROTECT



FIXTURE

## Safety Xtreme Round, Square & X-Frame bollards, & Reflex Bollards

Offers extreme protection for safeguarding people and property from impact.

Bollards are engineered for high-traffic zones and forklift pathways. CRASH TEST RATING: ASTM F3016 S20 \*Certified to stop a 5000lb vehicle traveling at 20mph

Boston Group

Corporate Headquarters 3 Highwood West, Suite 100, Tewksbury, MA 01876 Tel. 781-395-7417 — 800-225-1633 (toll-free) — sales.us@boston-group.com

European Headquarters Sydneystraat 15, Rotterdam, 3047 BP, Netherlands Tel. +31 10 238 14 00 — sales.emea@boston-group.com. [www.boston-group.com](http://www.boston-group.com)

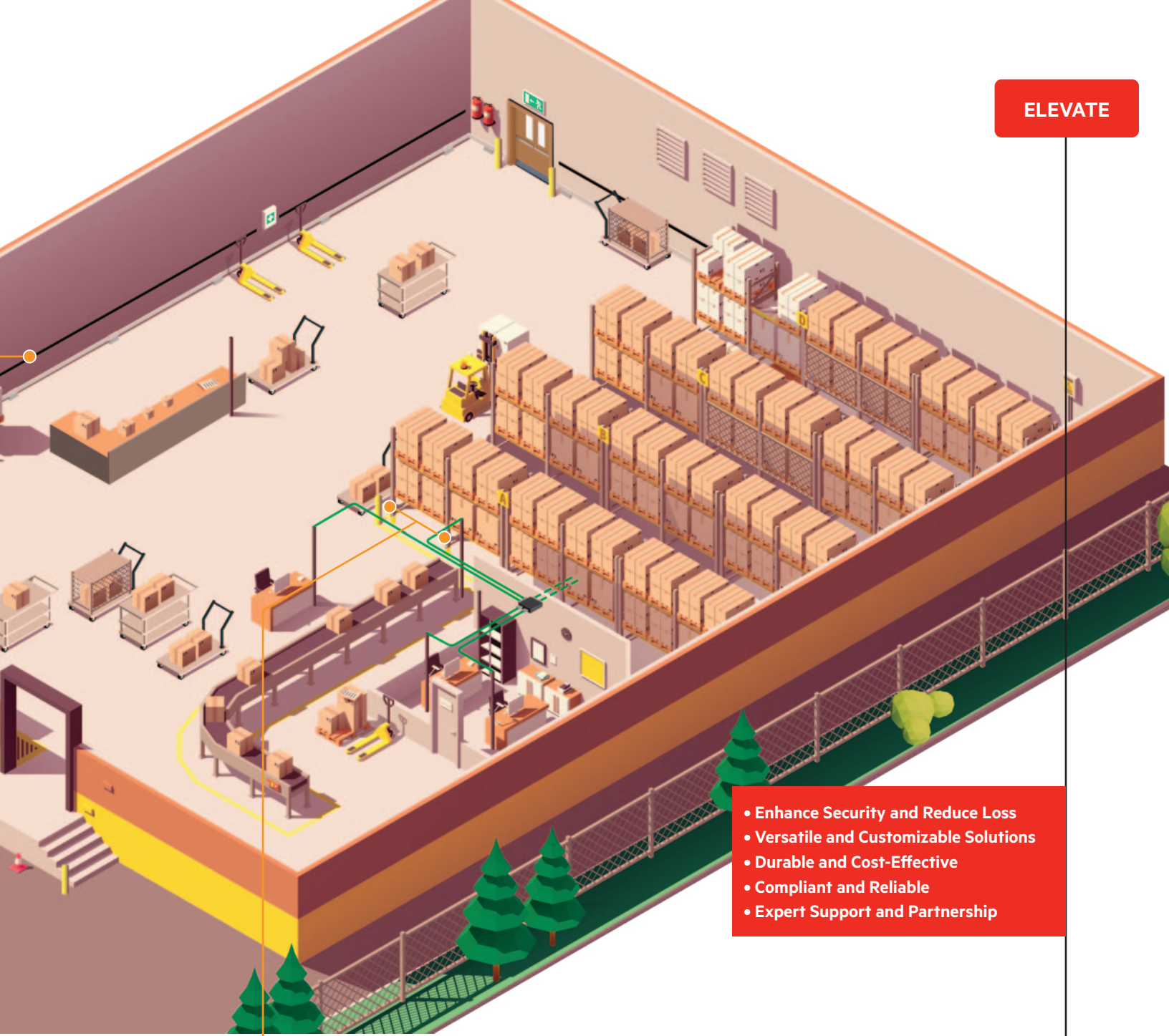

- Enhance Security and Reduce Loss
- Versatile and Customizable Solutions
- Durable and Cost-Effective
- Compliant and Reliable
- Expert Support and Partnership



**Boston Group's Back-of-House (BOH)**

This product line is engineered to safeguard your warehouse infrastructure from the rigors of daily operations. Designed for durability, visibility, and ease of installation, these solutions are ideal for distribution centers, logistics hubs, and industrial environments.

- **Pallet Rack Protection**  
Built to prevent costly damage to racking systems. Available in a wide range of colors.
- **Box Rail Impact Protection**  
High-profile, heavy-duty rail designed to absorb and deflect impacts.





# FIXTURE

## Service Desks and Admin Work/Pack Stations

### Modular Workstations Built for Performance and Flexibility

Boston Group's Service Desks are designed to meet the evolving needs of warehouse environments. Our desks and cabinets offer a seamless blend of durability, adaptability, and integrated technology. More than just furniture—our solutions are smart and scalable to support your team and streamline your operations.

- **Modular Design**

Easily configurable to fit any space or workflow.

- **Durable Materials**

Built to last in high-traffic environments, using robust materials that resist wear and tear.

- **Sustainable & Stylish**

Available in a wide range of colors and finishes, with components that are 100% recyclable.

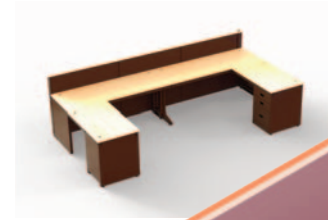

## Fixed and Rolling Tables Built for the Demands of Modern Warehousing

### High-performance tables and workstations engineered for the fast-paced environments of warehouses and distribution centers.

Whether you need fixed tables for stability and heavy-duty tasks or rolling tables for flexible, mobile workflows — we've got you covered.

- **Durable Construction**

Built to withstand daily wear and tear in high-traffic industrial settings.

- **Customizable Options**

Choose from a variety of sizes, surfaces, and configurations to meet your exact needs.

- **Mobility When You Need It**

Our rolling tables offer smooth maneuverability without compromising strength.

- **Ergonomic Design**

Improve worker comfort and productivity with thoughtfully designed work surface.

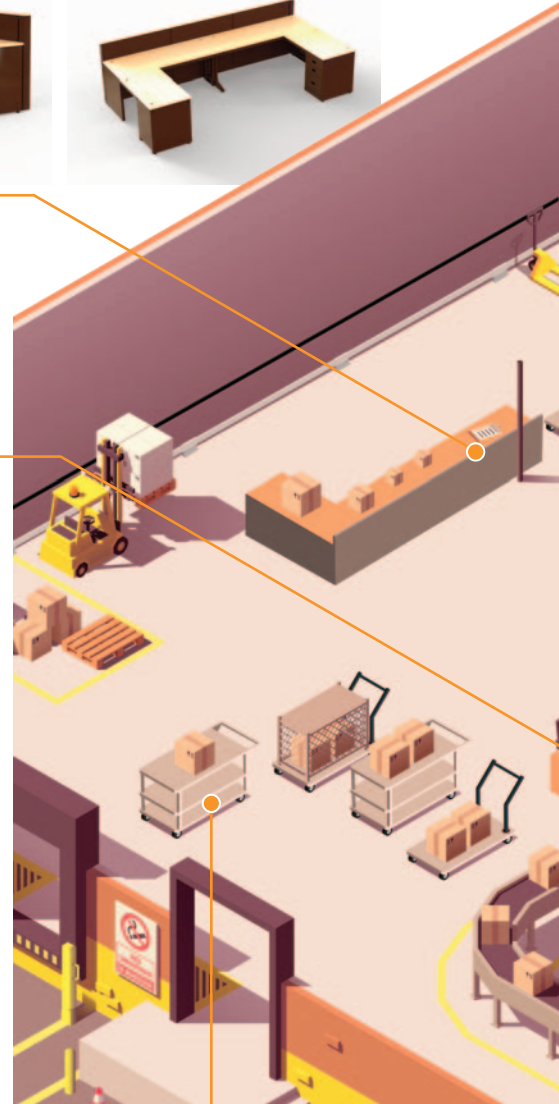

POWER



PROTECT



FIXTURE

### Boston Carts

The Boston Cart is a robust line of durable, versatile carts that hold, move and secure an array of items for multiple environments. Available in your choice of colors, these carts are fully configurable with various options for locking (for general merchandise and high security locking applications).



Boston Group

**Corporate Headquarters** 3 Highwood West, Suite 100, Tewksbury, MA 01876 Tel. 781-395-7417 — 800-225-1633 (toll-free) — sales.us@boston-group.com

**European Headquarters** Sydneystraat 15, Rotterdam, 3047 BP, Netherlands Tel. +31 10 238 14 00 — sales.emea@boston-group.com. [www.boston-group.com](http://www.boston-group.com)

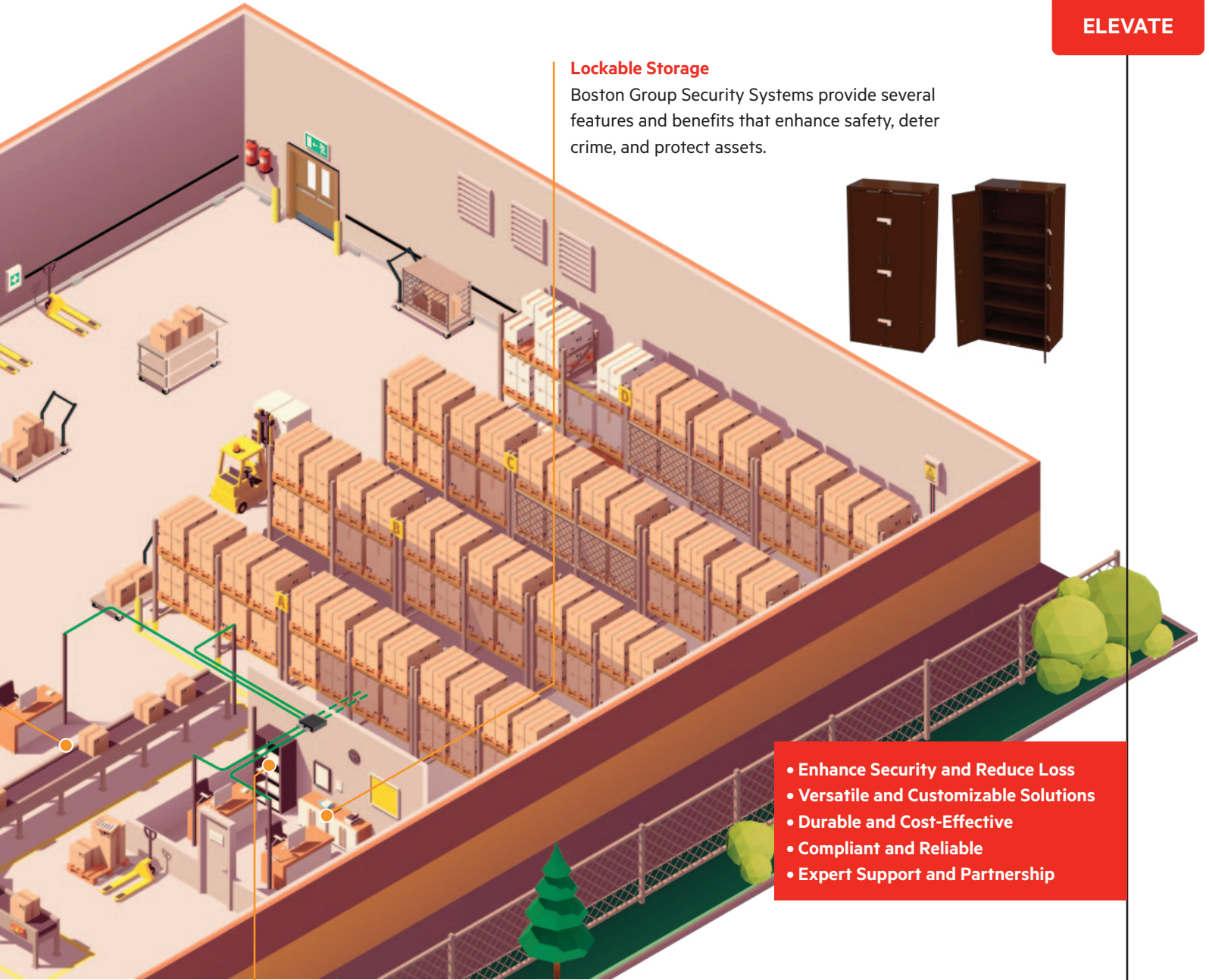

**Lockable Storage**

Boston Group Security Systems provide several features and benefits that enhance safety, deter crime, and protect assets.



- Enhance Security and Reduce Loss
- Versatile and Customizable Solutions
- Durable and Cost-Effective
- Compliant and Reliable
- Expert Support and Partnership



**Cages and Security Doors**

Ideal for securing valuable products with rugged tubular frame construction.

**Loss Prevention Solutions for Interior and Exterior Uses**

**Boston Group's Security Gates and Cages are engineered to provide robust protection for high-value merchandise and sensitive areas.**

Designed with both functionality and aesthetics in mind, these solutions help deter theft, enhance safety, and maintain visibility.

**Durable Construction**

- Made from steel, aluminum, and plexiglass for long-lasting performance.
- Optional multi-point locking systems for enhanced security.

**Flexible Configurations**

- Available in custom sizes.
- Numerous options for doors and locking mechanisms.
- Powder-coated frames in any desired color.





# POWER

## FASTLANE® Total Store 'Plug&Play' System

Boston Group's FastLane® modular wiring solutions are cost-effective 'Plug & Play' wiring methods that carry power and voice/data from electrical and computer patch panels to your selling floor.

Our FastLane® wiring solutions are custom designed and configured to meet your specific needs while still allowing for a 100% functional, pre-tested modular installation. The system arrives 'as-designed' to eliminate hard wiring and 'on-the-fly design' common with traditional methods. Save installation time and labor costs with quick, reliable connections from the switch gear to point-of-use.



FASTLANE® Total 'Plug&Play' System

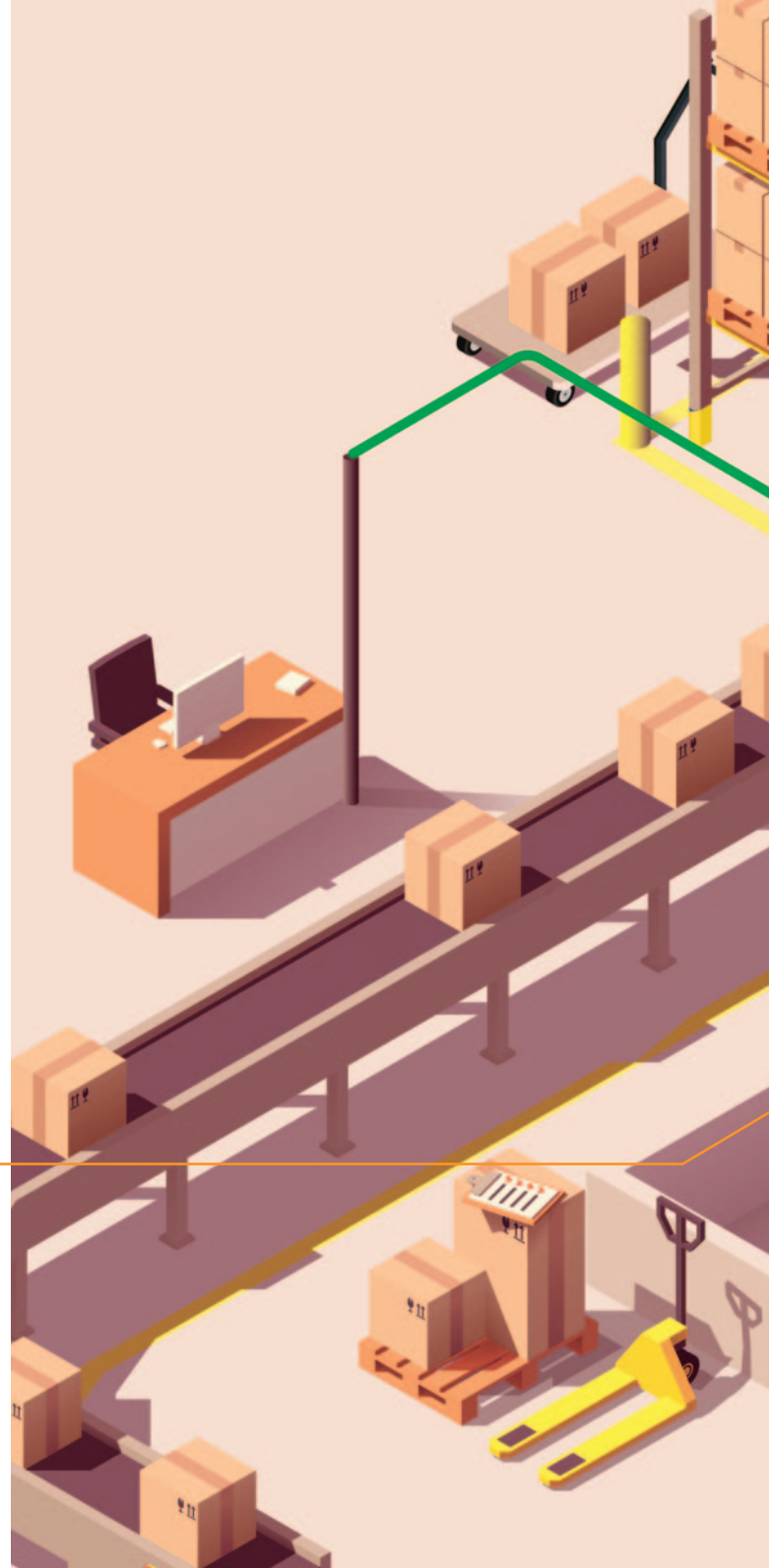
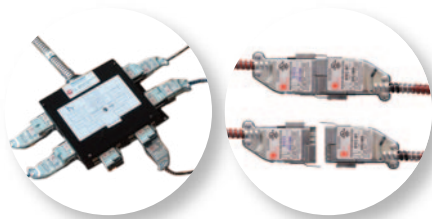

# POWER



# PROTECT



# FIXTURE

**Our total end to end solution of product and service provides power to all areas of a warehouse: lighting, office and service areas. Currently, our systems are installed in thousands of locations across US, Canada and Mexico.**

ELEVATE

- Enhance Security and Reduce Loss
- Versatile and Customizable Solutions
- Durable and Cost-Effective
- Compliant and Reliable
- Expert Support and Partnership

Power Poles



**Power Poles**

Boston Group offers a wide range of PowerPole product solutions that fulfill any power/voice and data distribution needs with UL compliant, reliable 'plug & play' connectors.





### Integrated Design & Manufacturing

Boston Group combines metal, wood, plastic, power, lighting, and technology into modular designs that seamlessly integrate into any warehouse environment. Our team of engineers and designers work closely with you to deliver scalable, cost-effective solutions that meet your operational goals. Boston Group is your partner in creating smarter, safer, and more efficient warehouse spaces. Let us help you transform your distribution center into a high-performance hub.

### Expert Support and Partnership:

We don't just sell products; we build long-term partnerships. Our team offers expert advice, installation support, and ongoing service to ensure that your stores operate at their highest potential.



POWER



PROTECT



FIXTURE

Boston Group



**Corporate Headquarters** 3 Highwood West, Suite 100, Tewksbury, MA 01876 Tel. 781-395-7417 — 800-225-1633 (toll-free) — [sales.us@boston-group.com](mailto:sales.us@boston-group.com)

**European Headquarters** Sydneystraat 15, Rotterdam, 3047 BP, Netherlands Tel. +31 10 238 14 00 — [sales.emea@boston-group.com](mailto:sales.emea@boston-group.com) [www.boston-group.com](http://www.boston-group.com)



# ELEVATE Your Hardware Store Experience with Our Comprehensive Solutions

The combination of customer satisfaction, security, customization, durability, compliance, efficiency, along with our expertise and partnership, are an essential part of enhancing the operational success of hardware store chains.



POWER



PROTECT



FIXTURE



Boston Group

**Corporate Headquarters** 3 Highwood West, Suite 100, Tewksbury, MA 01876 Tel. 781-395-7417 — 800-225-1633 (toll-free) — [sales.us@boston-group.com](mailto:sales.us@boston-group.com)

**European Headquarters** Sydneystraat 15, Rotterdam, 3047 BP, Netherlands Tel. +31 10 238 14 00 — [sales.emea@boston-group.com](mailto:sales.emea@boston-group.com) — [www.boston-group.com](http://www.boston-group.com)

MADE IN THE USA • V SEPT 2025



# PROTECT

## Bumpers & Asset Protection

For over 85 years Boston Group has set the standard with its full line of floor and wall mounted bumpers, and crash rails for retailers. With over a decade of being a UL Environment Certified company (the only bumper manufacturer with this certification), we are proud to have placed great emphasis on incorporating recycled material in our product design and manufacture.



- Maximize Customer Satisfaction
- Enhance Security and Reduce Loss
- Versatile and Customizable Solutions
- Durable and Cost-Effective
- Compliant and Reliable
- Expert Support and Partnership

## Guidance & Security Railing System Stainless Steel

These railings help guide customers, prevent accidents, and create a secure atmosphere. They serve to clearly mark entrances, exits, paths, and cart areas to help customers navigate the store safely.



POWER



PROTECT



FIXTURE

## Round, Square or X-Frame Bollards

Extreme Storefront Protection for safeguarding customers and property from accidental or deliberate vehicle impacts. Can be powder coated or covered with Stainless Steel or colored plastic bollard covers. CRASH TEST RATING: ASTM F3016 S20  
\*Certified to stop a 5000lb vehicle traveling at 20mph

Change the appearance by adding a round cover to your bollard. Popular Cover Options - More Options Available Upon Request



Boston Group

Corporate Headquarters 3 Highwood West, Suite 100, Tewksbury, MA 01876 Tel. 781-395-7417 — 800-225-1633 (toll-free) — sales.us@boston-group.com

European Headquarters Sydneystraat 15, Rotterdam, 3047 BP, Netherlands Tel. +31 10 238 14 00 — sales.emea@boston-group.com. [www.boston-group.com](http://www.boston-group.com)



**FIXTURE**

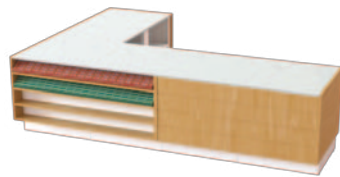

**Point of Service (POS), Counters, and Fixtures**

Boston Group's line of fixture and cabinet solutions for store environments offers durable modules that easily adapt to meet your needs. These fixtures can incorporate plug & play power and lighting elements to deliver fast and seamless integration. Unlimited and customized merchandising options are available.

**Gondola Doors: Single and Multiple Bays**

**Enhanced Security**

- Deters theft, vandalism, and unauthorized access.
- Protects valuable merchandise and store assets.
- Can be tailored to fit specific sizes and aesthetic requirements.

**Robust Construction**

- Made from durable and sustainable materials; steel, aluminum, and plexiglass.
- Optional multi-point locking systems for added security.



**POWER**

Power Poles



**Gondola Mounted Track Arm Displayer**

Allows to display light fixtures and ceiling fans easily and economically.



**VersaTrack**

Gondola or warehouse racking mounted display.

**Power Poles**

Boston Group offers a wide range of PowerPole product solutions that fulfill any power/voice and data distribution needs with UL compliant, reliable 'plug & play' connectors.



#### Maximize Customer Satisfaction:

Our stylish and functional counters and checkout areas enhance the shopping experience, allowing for a seamless flow of customers. Well-designed fixtures reduce wait times and improve service efficiency, resulting in happier customers and increased loyalty.

#### Enhance Security and Reduce Loss:

Our state-of-the-art asset protection and loss prevention products safeguard your inventory and mitigate theft. By implementing our solutions, convenience stores can significantly reduce shrinkage, leading to improved profit margins and protecting your bottom line.

#### Compliant and Reliable:

Our solutions meet all industry standards for safety and functionality. By choosing our products, you can trust that you're equipping your stores with reliable solutions that comply with regulations and provide peace of mind.

#### Versatile and Customizable Solutions:

Our fixtures are designed to adapt to the unique layout and branding of your stores. With customizable options, we ensure that your convenience store stands out while effectively utilizing space for optimal product visibility and sales.

#### Expert Support and Partnership:

We don't just sell products; we build long-term partnerships. Our team offers expert advice, installation support, and ongoing service to ensure that your stores operate at their highest potential.

#### Durable and Cost-Effective:

Crafted from high-quality materials, our fixtures are built to last. Investing in our durable products means fewer replacements, lower maintenance costs, and greater long-term value for your stores.



POWER



PROTECT



FIXTURE

Boston Group



**Corporate Headquarters** 3 Highwood West, Suite 100, Tewksbury, MA 01876 Tel. 781-395-7417 — 800-225-1633 (toll-free) — [sales.us@boston-group.com](mailto:sales.us@boston-group.com)

**European Headquarters** Sydneystraat 15, Rotterdam, 3047 BP, Netherlands Tel. +31 10 238 14 00 — [sales.emea@boston-group.com](mailto:sales.emea@boston-group.com) [www.boston-group.com](http://www.boston-group.com)



# **ELEVATE** Your **Lighting Showroom** Experience with Our Comprehensive Solutions

The combination of customer satisfaction, security, customization, durability, compliance, efficiency, along with our expertise and partnership, are an essential part of enhancing the operational success of lightening showroom chains.



POWER



PROTECT



FIXTURE



Boston Group

**Corporate Headquarters** 3 Highwood West, Suite 100, Tewksbury, MA 01876 Tel. 781-395-7417 — 800-225-1633 (toll-free) — [sales.us@boston-group.com](mailto:sales.us@boston-group.com)

**European Headquarters** Sydneystraat 15, Rotterdam, 3047 BP, Netherlands Tel. +31 10 238 14 00 — [sales.emea@boston-group.com](mailto:sales.emea@boston-group.com) [www.boston-group.com](http://www.boston-group.com)

MADE IN THE USA • V SEPT 2025



# POWER

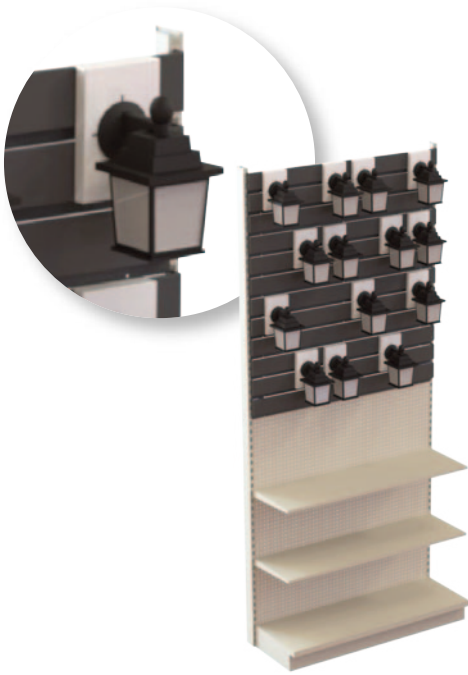

### VersaPanel®

Boston's VersaPanel® is a versatile merchandising system that powers and displays lighting fixtures. Standard or custom finished face plates include the possibility for power access every 5 cm (2"), both horizontally and vertically:

- Merchandise more in less space. Higher density displays leave more room for merchandise and graphic communications.
- Create a unique selling environment. Free-standing, suspended, wall, pallet racking & gondola platform options.
- Wide range of standard accessories with unlimited possibilities. Integrate duplex outlets, shelving, hooks, graphics and more to display product in their best light.

### VersaTrack

#### Features:

- Track construction allows variable display height
- Simple and safe plug n play design
- Durable construction and economical
- Can be powder coated in any color
- 125V/60hz/15A/1500W per assembled panels
- Additional power inserts can be added as needed
- Weight load capacity of 45lbs per single slat panel
- Can install on walls, gondola shelving and warehouse racking

#### Benefits:

- Unlimited and flexible merchandising options
- Aesthetic and can match your branding

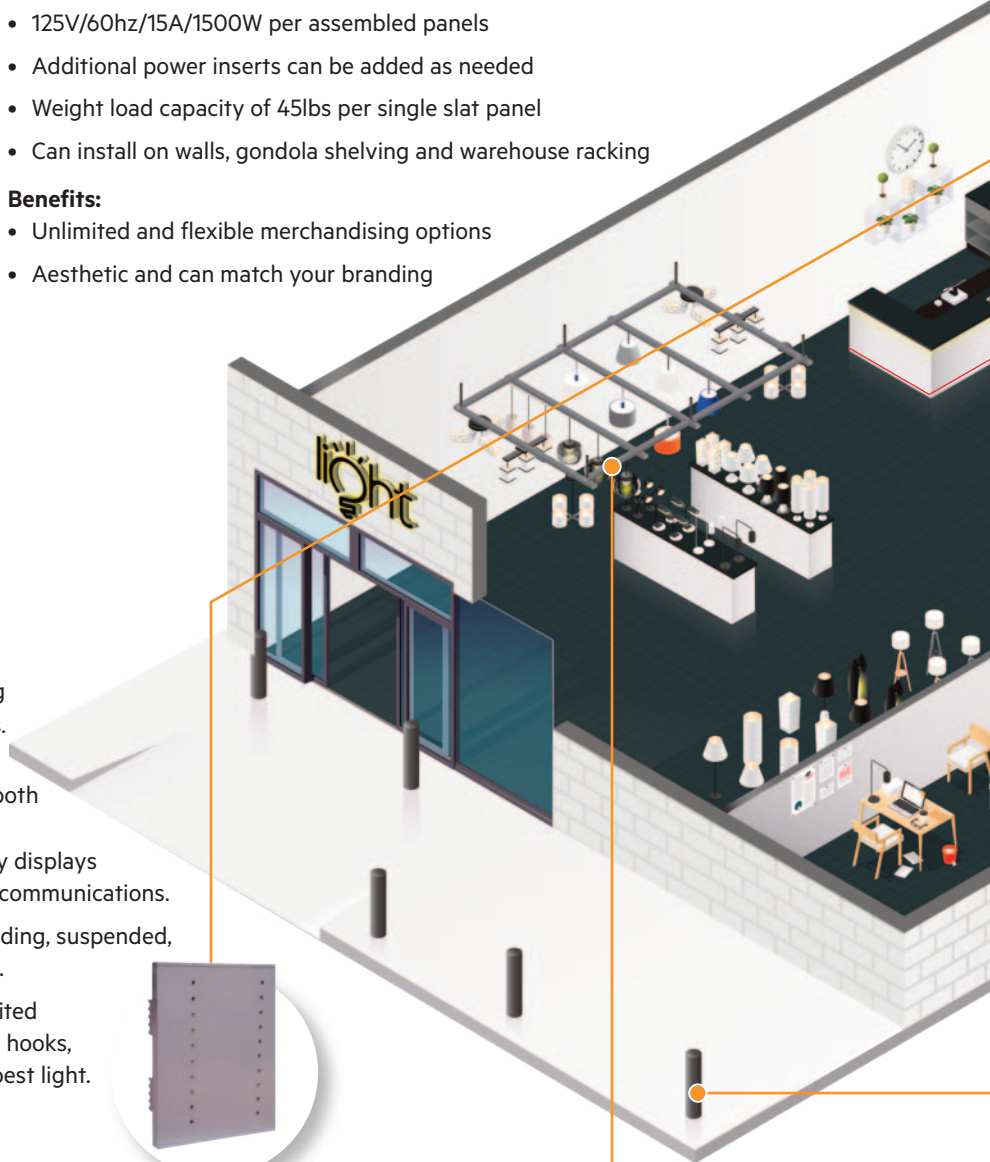

# POWER



# PROTECT



# FIXTURE

### Hanging Track Clouds with PowerTrack™

Boston PowerTrack™ offers a simple certified and approved solution for displaying powered and non-powered lighting fixtures. Built using channel lengths from 2'-12' and with standard receptacle spacing of 12" or 18" on center, Boston PowerTrack™ can easily be configured to meet your specific display needs. Available in 120V and 230V.



Boston Group

Corporate Headquarters 3 Highwood West, Suite 100, Tewksbury, MA 01876 Tel. 781-395-7417 — 800-225-1633 (toll-free) — sales.us@boston-group.com

European Headquarters Sydneystraat 15, Rotterdam, 3047 BP, Netherlands Tel. +31 10 238 14 00 — sales.emea@boston-group.com. [www.boston-group.com](http://www.boston-group.com)



FIXTURE

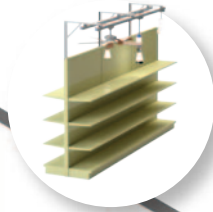
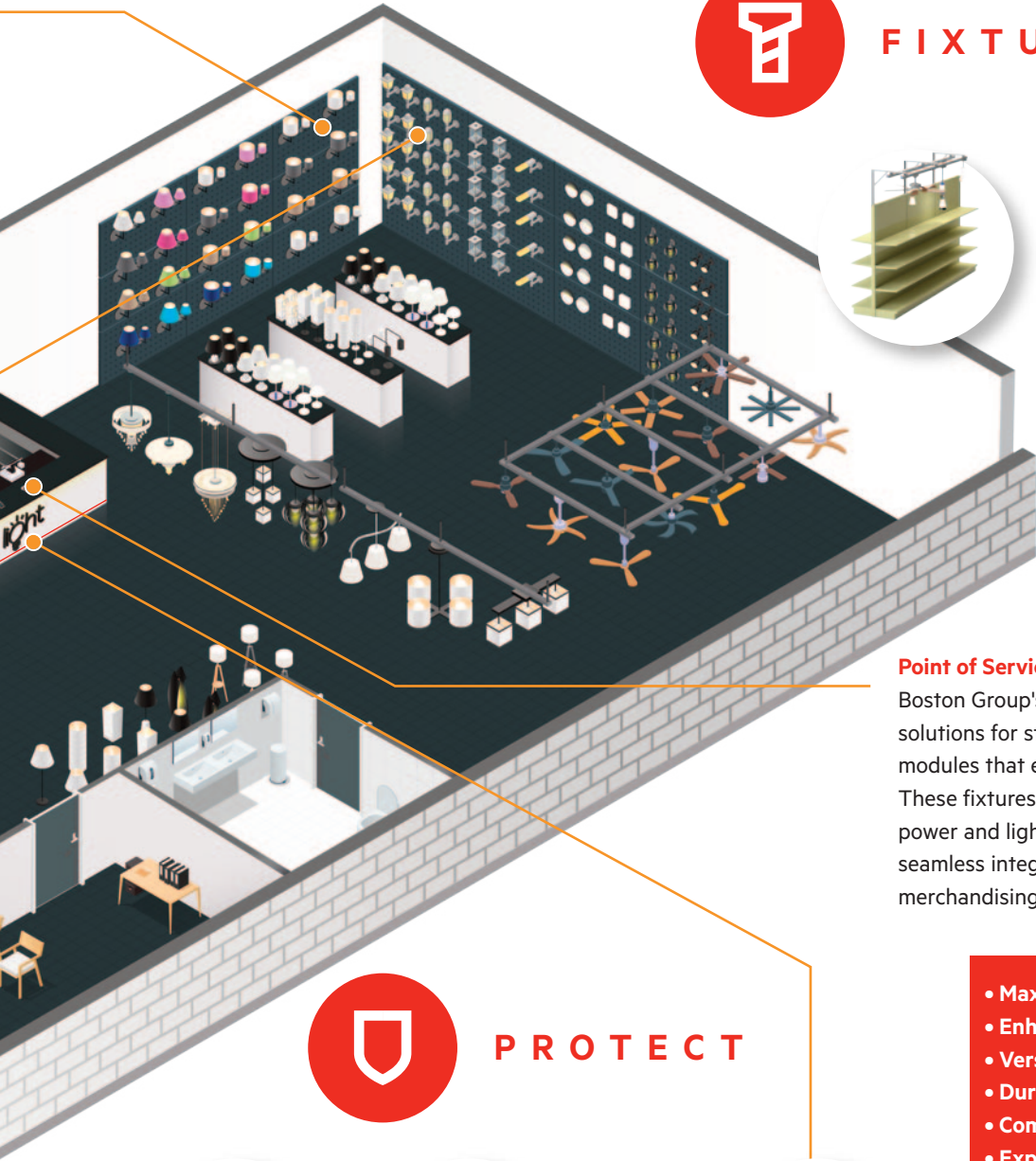

**Gondola Mounted Track Arm Displayer**  
Allows to display light fixtures and ceiling fans easily and economically.

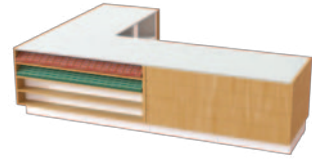

**Point of Service (POS), Counters, and Fixtures**  
Boston Group's line of fixture and cabinet solutions for store environments offers durable modules that easily adapt to meet your needs. These fixtures can incorporate plug & play power and lighting elements to deliver fast and seamless integration. Unlimited and customized merchandising options are available.



PROTECT

- Maximize Customer Satisfaction
- Enhance Security and Reduce Loss
- Versatile and Customizable Solutions
- Durable and Cost-Effective
- Compliant and Reliable
- Expert Support and Partnership

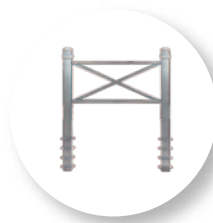
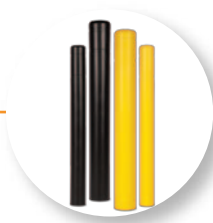

**Round, Square or X-Frame Bollards**  
Extreme Storefront Protection for safeguarding customers and property from accidental or deliberate vehicle impacts. Can be powder coated or covered with Stainless Steel or colored plastic bollard covers. CRASH TEST RATING: ASTM F3016 S20  
\*Certified to stop a 5000lb vehicle traveling at 20mph

**Bumpers & Asset Protection**  
For over 85 years Boston Group has set the standard with its full line of floor and wall mounted bumpers, and crash rails for retailers.

Change the appearance by adding a round cover to your bollard. Popular Cover Options - More Options Available Upon Request





#### Maximize Customer Satisfaction:

Our stylish and functional counters and checkout areas enhance the shopping experience, allowing for a seamless flow of customers. Well-designed fixtures reduce wait times and improve service efficiency, resulting in happier customers and increased loyalty.

#### Enhance Security and Reduce Loss:

Our state-of-the-art asset protection and loss prevention products safeguard your inventory and mitigate theft. By implementing our solutions, convenience stores can significantly reduce shrinkage, leading to improved profit margins and protecting your bottom line.

#### Versatile and Customizable Solutions:

Our fixtures are designed to adapt to the unique layout and branding of your stores. With customizable options, we ensure that your convenience store stands out while effectively utilizing space for optimal product visibility and sales.

#### Compliant and Reliable:

Our solutions meet all industry standards for safety and functionality. By choosing our products, you can trust that you're equipping your stores with reliable solutions that comply with regulations and provide peace of mind.

#### Expert Support and Partnership:

We don't just sell products; we build long-term partnerships. Our team offers expert advice, installation support, and ongoing service to ensure that your stores operate at their highest potential.

#### Durable and Cost-Effective:

Crafted from high-quality materials, our fixtures are built to last. Investing in our durable products means fewer replacements, lower maintenance costs, and greater long-term value for your stores.



POWER



PROTECT



FIXTURE

Boston Group



**Corporate Headquarters** 3 Highwood West, Suite 100, Tewksbury, MA 01876 Tel. 781-395-7417 — 800-225-1633 (toll-free) — [sales.us@boston-group.com](mailto:sales.us@boston-group.com)

**European Headquarters** Sydneystraat 15, Rotterdam, 3047 BP, Netherlands Tel. +31 10 238 14 00 — [sales.emea@boston-group.com](mailto:sales.emea@boston-group.com) [www.boston-group.com](http://www.boston-group.com)



M 7

# ELEVATE Your Door+Window Extrusion Experience with Our Comprehensive Solutions

At Boston Group, we help shape our customer's success by working as partners to understand problems, develop solutions, and deliver Door and Window extrusions that attain a superior standard of excellence in Quality, Value, and Choice. Boston Group has the capability to manufacture standard and custom dies utilizing wire EDM and, as a result, we can centralize and control each step of the process ensuring quality, competitive pricing and reduced lead times.



POWER



PROTECT



FIXTURE

Boston Group



**Corporate Headquarters** 3 Highwood West, Suite 100, Tewksbury, MA 01876 Tel. 781-395-7417 — 800-225-1633 (toll-free) — [sales.us@boston-group.com](mailto:sales.us@boston-group.com)

**European Headquarters** Sydneystraat 15, Rotterdam, 3047 BP, Netherlands Tel. +31 10 238 14 00 — [sales.emea@boston-group.com](mailto:sales.emea@boston-group.com) — [www.boston-group.com](http://www.boston-group.com)

MADE IN THE USA • V SEPT 2025

# Door + Window Extrusions

## Better Quality, Performance and Choice

Boston Group's impressive and extensive inventory of Door and Window shapes/profiles allows reliable and rapid response to customer requirements. In addition, our Design Engineers utilize the latest developments in CAD/CAM technology to create designs for a broad range of unique extrusions.

Boston Group offers a wide array of extrusions to seal and insulate doors and windows from external elements and for structural support. Our material versatility includes Rigid and Flexible PVC, Santoprene, ABS, TPR and TPE.

Although our standard colors in Door and Window applications are black, almond, dark brown, and white, Boston Group offers a broad range of custom colors. By means of precise spectropho-

tometer color matching, we can match and produce virtually any color. Custom colors are retained permanently in our color inventory, so color consistency is guaranteed every time.

We maintain over 10,000 Door and Window die profiles. The availability of this inventory allows for a more rapid response to customer requirements by avoiding time delays in development and reducing the cost of die profiles.

Our impressive range of extrusion options are produced at the company's state-of-the-art facility in Ohio.

**Our reputation ensures superior quality stock and custom products tailored to the specific requirements of our customer – all delivered on time and on budget.**

### Certification & Compliance

Every product we make adheres to strict third party national safety standards for mechanical, electrical and environmental compliance.

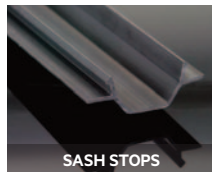
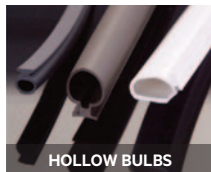

#### Glass Splines

DIM	DESCRIPTION	RANGE
A	Overall Width	.290" - .620"
B	Lock	.110" - .250"
C	Overall Height	.135" - .370"

#### Hollow Bulbs

DIM	DESCRIPTION	RANGE
A	Base	.095" - .400"
B	Throat	.045" - .125"
C	Height	.290" - .500"
D	Width	.100" - .450"

#### Standard U-Channels

DIM	DESCRIPTION	RANGE
A	Base	.080" - 1.060"
B	Penetration	.160" - .600"
C	Rib Width	.040" - .165"
D	Bead Width	.060" - .250"
N	Number of Ribs	0 - 4 (I/O/B)*

#### 4 Hole Hollow U-Channels

DIM	DESCRIPTION	RANGE
A	Base	.080" - .260"
B	Penetration	.400" - .500"
C	Rib Width	.160" - .340"
D	Bead Width	.200" - .420"
N	Number of Ribs	0 - 4 (I/O/B)*

#### Glazing Beads

DIM	DESCRIPTION
A	Overall Height
B	Overall Width
C	Thickness

Per customer's specifications

#### Sash Stops

DIM	DESCRIPTION
A	Overall Height
B	Overall Width
C	Thickness

#### Sweeps/Expanders

DIM	DESCRIPTION	RANGE
A	Length	.300" - 1.250"
B	Base	.100" - .300"



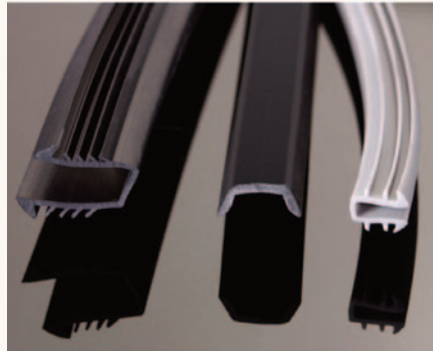

## Here are just some of the products we offer:

- Glass Splines
- U-Channels
- Glazing Beads
- Filler Strips
- Sash Stops
- Hollow Bulbs
- Rigid Guides
- Wedge Gaskets
- Sweeps and Expanders
- Dual Extrusion Hollow Bulbs
- Covers/Thresholds
- Thermal Brake





## Ordering information

Please call 330-744-8100.

A minimum charge will apply on short production runs.

Standard products delivery is 10-15 days.

All prices quoted FOB, Ohio.

Please specify color and packaging requirements.



POWER



PROTECT



FIXTURE

Boston Group



**Corporate Headquarters** 3 Highwood West, Suite 100, Tewksbury, MA 01876 Tel. 781-395-7417 — 800-225-1633 (toll-free) — [sales.us@boston-group.com](mailto:sales.us@boston-group.com)

**European Headquarters** Sydneystraat 15, Rotterdam, 3047 BP, Netherlands Tel. +31 10 238 14 00 — [sales.emea@boston-group.com](mailto:sales.emea@boston-group.com) [www.boston-group.com](http://www.boston-group.com)

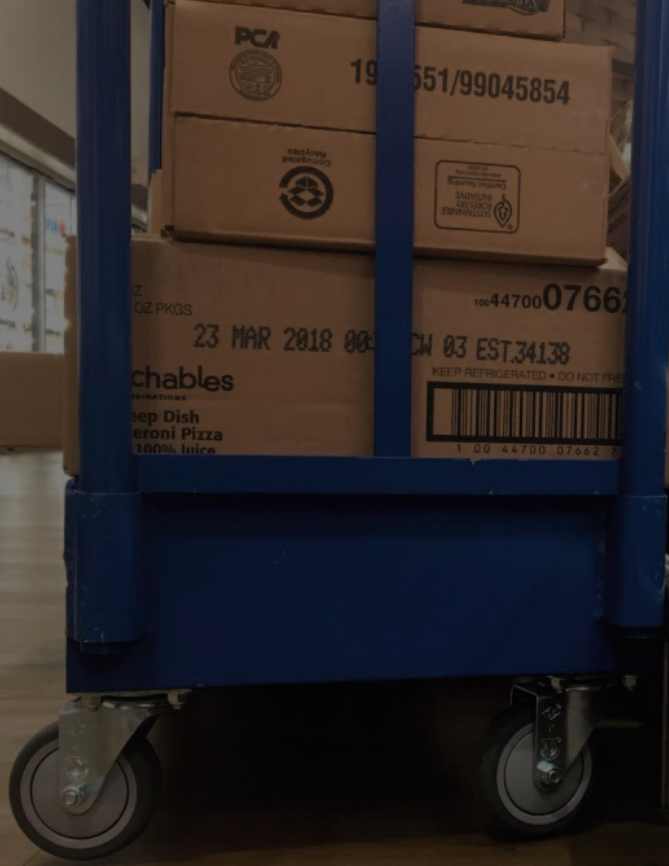

M 8

# ELEVATE Your OEM Profiles Experience with Our Comprehensive Solutions

Boston Group's expertise and experience in assessing asset protection needs and applying the correct type of manufactured products with top notch survey, service and deployment ensures you get the best value. Everything taken care of... to the very last detail!

-  POWER
-  PROTECT
-  FIXTURE



**Boston Group**

**Corporate Headquarters** 3 Highwood West, Suite 100, Tewksbury, MA 01876 Tel. 781-395-7417 — 800-225-1633 (toll-free) — [sales.us@boston-group.com](mailto:sales.us@boston-group.com)  
**European Headquarters** Sydneystraat 15, Rotterdam, 3047 BP, Netherlands Tel. +31 10 238 14 00 — [sales.emea@boston-group.com](mailto:sales.emea@boston-group.com) [www.boston-group.com](http://www.boston-group.com)















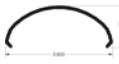

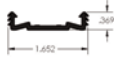



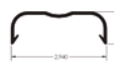





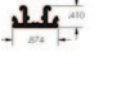



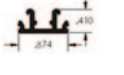

MADE IN THE USA • V SEPT 2025

# OEM Profiles

## Custom Extrusion Solutions

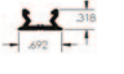
**Custom OEM Profiles. If you need it - we can make it!**

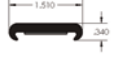
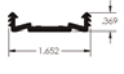
Boston Group's custom extrusion products are the key components in the most versatile and effective damage protection system available today.

PART	DESCRIPTION	PART	DESCRIPTION	PART	DESCRIPTION	PART	DESCRIPTION
	101-6311 Custom Rigid Extrusion		101-5714 Rigid Base, 3" Bumper System		101-6055 Master Bumper Base		PBTR2000 Poly, Top, 2000 Series
	101-0539 4" Impact Bumper Top		101-6067 Nose Bumper, Flexible, Capstock		101-6056 Master Bumper		PBTR2000 POLY, Base, 2000 Series
	101-0686 3" Impact Bumper		101-5260 Vertical Pole for Water and Electrical Routing		101-6217 Raceway		TR3000 Top, Rigid, 3000 Series
	101-6136 3" Profile (101-0686) bent 90° to 2" radius		101-6494 Rigid Bumper		TFC1000 1" Top, Flexible, Cap Stock, 1000 Series		BR3000 Base Rigid 3000 Series
	101-6293 3" Profile (101-0686) bent 135° to 2" radius		101-0534 Rigid Bumper Base Channel		BR1000 w/Screw Ribs Base, Rigid, 1000 Series, Regrind		PBTR3050 Poly, Top, 3050 Series
	101-6294 4" Profile (101-0539) bent 135° to 3" radius		101-5993 Cornice Trim		PBTR1000 Poly, Top, 1000 Series		PBTR3050 Polybutylene Base, 3050 Series
	101-6072 4" Profile (101-0539) bent 90° to 3" radius		101-6061 Rigid Edge Trim		PBTR1000 Poly, Base, 1000 Series		TFC3300 Top, Flex, Capstock, 3300 Series
	101-6176 3" Profile End Cap		101-5502 Ticket Strip Holder for 1.25" Tag		SFC1000 1" SuperFlex Insert, ECO		BA3300 A-40 Aluminum Base
	101-6051 3" Bumper, Ribbed, Rigid				BRSF1000 1" SuperFlex Channel		ETCG15-XXX Edge Trim, Cover, for 1.50" Board
					TFC2000 Top, Flexible, Capstock 2000 Series		ET1.25 Edge Trim, for 1.25" Panel
					BR2000 Bottom, Rigid		ET2 2.00" Wide Edge Trim



POWER



PROTECT



FIXTURE



FROM PRINT

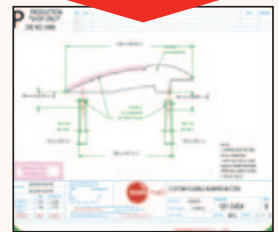

TO PRODUCT



TO APPLICATION



A wide range of colors, styles, and profiles ensures the look is right, but it's the high strength, durable compounds used in the extrusion process that offer the maximum protection against damage. Produced at the state-of-the-art facility in Ohio, these "bumpers" offer OEMs an impressive range of options for protecting vulnerable areas.



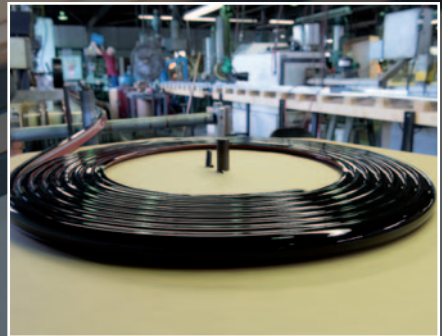

### Assessment & Survey

Our customer centric team of engineers, customer service and account managers will take the time to understand what type of asset protection is required.

### Planning

Upon completion of your needs assessment, Boston Group will provide you with:

- A detailed proposal for the right profile and placement depending on your operational and environmental needs.

- A deployment plan ensuring deliverables are clear and time tables are maintained.

### Production & Manufacturing

We are the original manufacturer. In fact, we invented the category of retail asset protection with the Boston Bumper! Come visit any one of our manufacturing facilities and see how we make our bumpers, end-caps, rails and corner guards. Our doors are always open!

### Certification & Compliance

Every product we make adheres to strict third party national standards for mechanical, electrical and environmental compliance.



POWER



PROTECT



FIXTURE

### Deployment & Installation

Our expert customer service and logistics team will deploy your items when and where you need them. Boston Group's experienced staff of engineers and product management are with you every step of the way to supervise and support a seamless integration.



Boston Group

**Corporate Headquarters** 3 Highwood West, Suite 100, Tewksbury, MA 01876 Tel. 781-395-7417 — 800-225-1633 (toll-free) — sales.us@boston-group.com

**European Headquarters** Sydneystraat 15, Rotterdam, 3047 BP, Netherlands Tel. +31 10 238 14 00 — sales.emea@boston-group.com. [www.boston-group.com](http://www.boston-group.com)

MADE IN THE USA • V SEPT 2025

Stand out from the crowd

# Fixture

Today's customer seeks a unique shopping experience and superb service. We can create your desired environment with our durable and flexible fixtures.

FIXTURE



# Ingenuity applied means finding you the best possible product

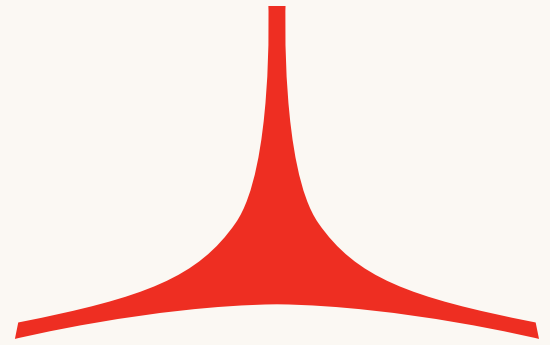

## Fixtures Applied at a Major Retailer

**Flexible pharmacy & quicker deployment**

Our client is a grocery, bakery, cheese shop, dry-cleaners, deli and full service pharmacy in one, with over 400 stores in the USA and still counting. Founded in the thirties and being a family-operated company – just like us – they serve more than 5 million customers annually.

**This Major Retailer wanted** to remodel their pharmacy department to improve upon its service levels and to create a smooth experience for both its customers and associates. They wanted a flexible yet durable fixture system that would fit into all their store formats.

**First, our cross-functional team** analyzed the problem and spoke to and worked together with different people in different departments. This way we got to understand their retail environment and were able to achieve improved speed and efficiency.

**We designed and developed** a modular and sustainable fixture system by bundling core elements of metal, wood, lighting, power, voice and data distribution and ensured our solution was UL and ADA compliant.

**The results?** Exactly what they had asked us for, and much more. Boston Group provided a fixture system that integrated electrical and mechanical features that shortened lead time from 8 to 4 weeks, consolidated multiple vendors and electricians and reduced overall costs.

**Now that's ingenuity applied.**

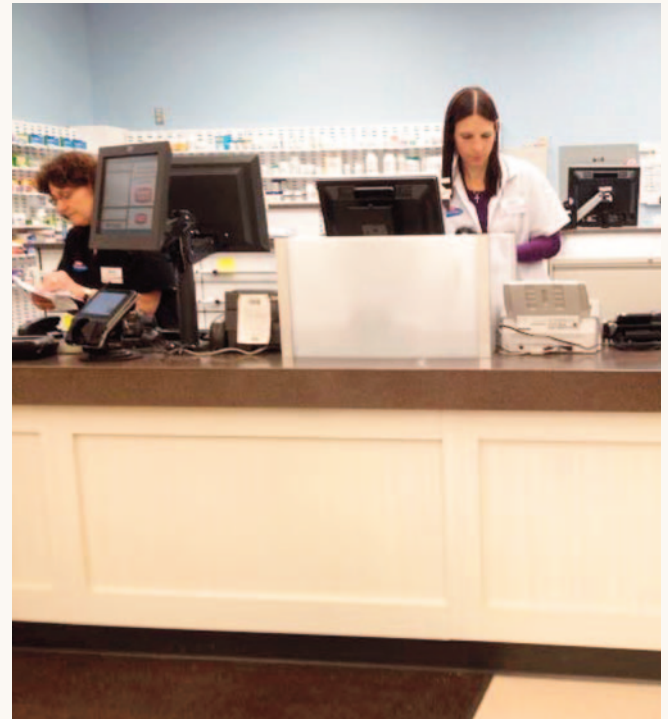

# Creative fixture solutions for any environment

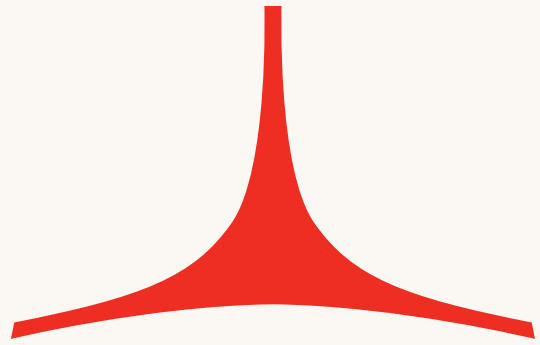

**Boston Group's fixture solutions bundle a variety of materials and components to create true value. Our unique system designs can integrate metal, wood, plastic, power and lighting in a modular format that fits seamlessly into any environment. Standard or custom, Boston Group has the ability to offer the right fixture to fill any need. That's Ingenuity Applied.**

Since 1937, we have been designing and manufacturing smart and cost-effective fixtures for all sorts of commercial environments, ranging from supermarkets and pharmacies to health care facilities and production sites.

Working with the best materials and latest technologies and relying on our craftsmanship and experience, we offer a custom solution for every commercial setting. Whatever you have in mind, we know how to make it special. With ingenuity and teamwork, we bring your ideas to life.

## Design, Simulation and Prototyping

See your ideas come to life before anything is built. Our advanced simulation software allows you to view your design in isolation or within a larger environment, in any color or finish and from any angle. We can prototype anything with our meticulous metal and plastic machinery, which can produce 1 to 1,000,000,000+ high precision products. This makes product development accurate, fast and efficient.

## Production & Manufacturing

Boston Group employs fully automated manufacturing cells that punch, bend, form and laser-cut to exact specifications, bridging concept to final product release. Our fully automated cells operate 24/7 and we can reduce lead times no matter how many products your project requires.

## Deployment & Installation

Our expert customer service and logistics team will deploy your items when and where you need them.

Boston Group's experienced staff of engineers and product management are with you every step of the way to supervise and support a seamless installation. Our global coverage includes offices and distribution centers in the US, Europe, Asia and Australia to supply worldwide support.

## Certification & Compliance

Every product we make adheres to strict third party national safety standards for mechanical, electrical and environmental compliance.



# It's all in the details

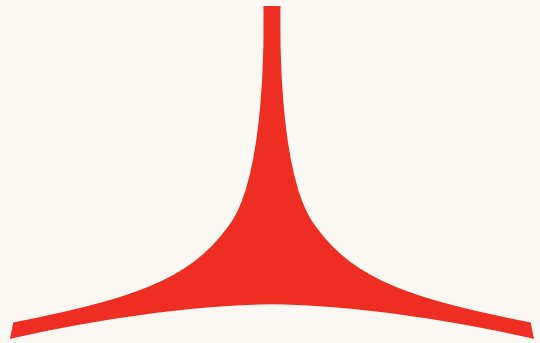

**Let our design, engineering and manufacturing experts help invigorate your environment**

Boston Group, founded in 1937, offers the very latest in design and manufacturing to turn your projects around quickly from concept to finished solutions.

## Integrated Solutions Philosophy

Boston Group designs and manufactures fixtures that bundle a variety of core materials (metal, wood, plastic, power, lighting and technology) into a modular design that allows seamless integration into any environment. Ingenuity Applied!

### **Cutting edge capabilities**

To stay competitive, Boston Group continuously invests in it's manufacturing capabilities to provide value driven solutions, quickly and efficiently.

### **Insight and thoughtfulness**

Our people make it all happen. To make a project viable, we formulate cross-functional teams comprising of account managers, designers, purchasers manufacturing engineers and customers service support.

### **Experience with energy**

The philosophy of Boston Group is to generate true value for our customers. We take time to understand your goals and objectives and apply our extensive experience to create configurable and scalable solutions for your environment.

## Challenge us...

At Boston Group, we love a good challenge. We strive to learn and push boundaries, so give us your toughest problem and we'll come up with a solution that meets your needs and budget.

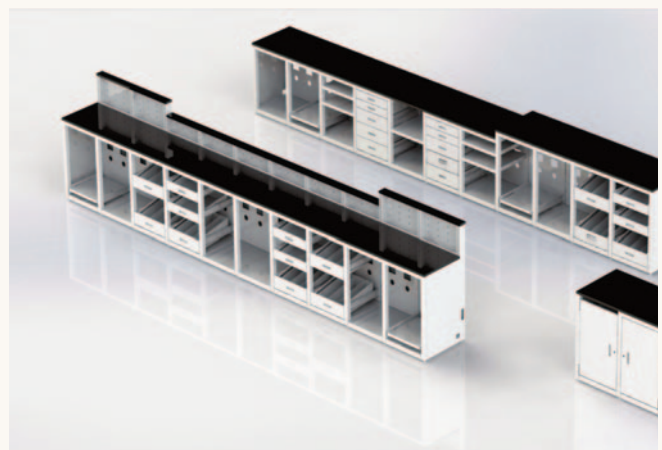

# Pharmacy Fixture Solutions

Design & Simulation | Production & Manufacturing

Boston Group's fixture solutions bundle a variety of materials and components to create true value. Our unique Pharmacy Fixture System integrates metal, wood, plastic, power and lighting in a modular design format that fits seamlessly into any environment. Standard or custom, Boston Group has the ability to offer the right fixture to fill any need. That's Ingenuity Applied.



## Applying ingenuity around the world.

Boston Group provides total solutions to energize environments, protect assets and support unique shopping or working experience. We listen carefully, look beyond the challenge and come up with smart solutions, exploring new domains every day together with you. From initial concept to full product rollout we expertly guide the process to deliver the right solutions for your needs.

### Pharmacy Module | #850-XXXX Fill Line



FIXTURE

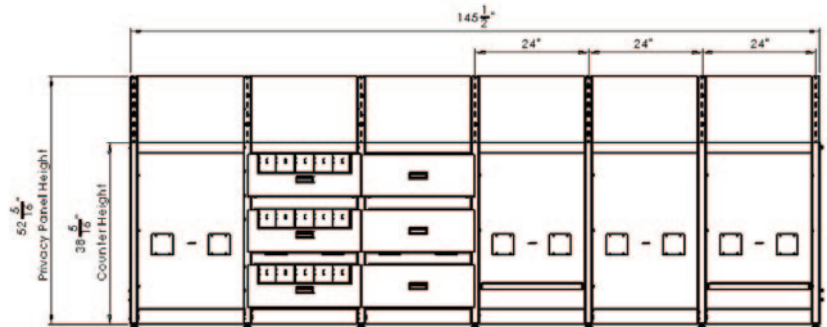
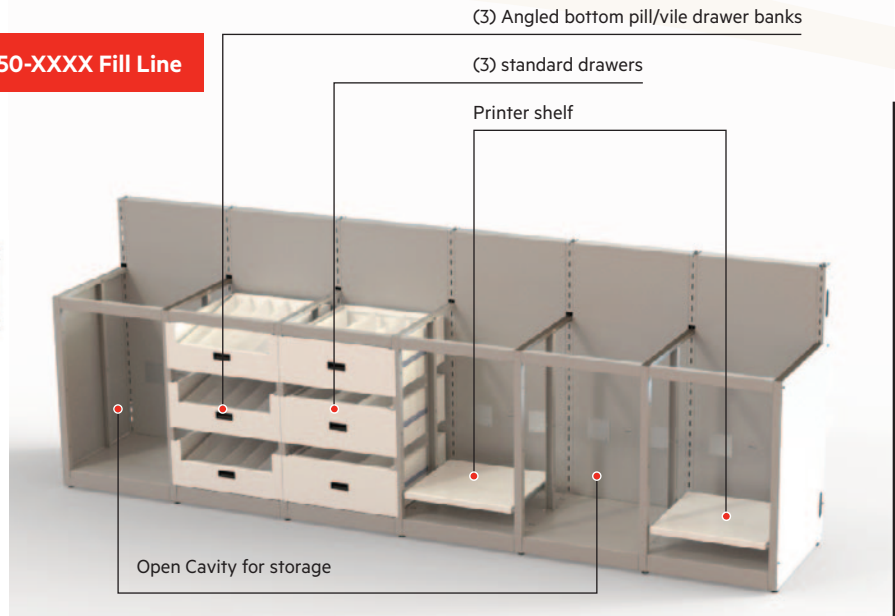
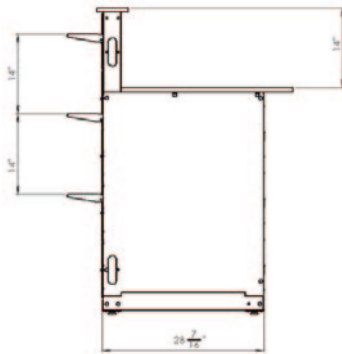

POWER



PROTECT



FIXTURE

Boston Group

Corporate Headquarters 3 Highwood West, Suite 100, Tewksbury, MA 01876 Tel. 781-395-7417 — 800-225-1633 (toll-free) — sales.us@boston-group.com

European Headquarters Sydneystraat 15, Rotterdam, 3047 BP, Netherlands Tel. +31 10 238 14 00 — sales.emea@boston-group.com. [www.boston-group.com](http://www.boston-group.com)

MADE IN THE USA • V SEPT 2025

# Pharmacy Fixture Solutions

Design & Simulation | Production & Manufacturing

## Materials & Construction

- Sturdy 16GA cold rolled steel construction
- Ships to customer site partially assembled to speed site installation
- Heavy duty adjustable leveling feet accommodates uneven floors
- Our state of the art Powder Coating line provides the most durable finishes in hundreds of color options
- Riveted corners for structural integrity
- Durable glides support 100lbs per shelf assembly

Angled bottom for self feeding products forward

16GA steel frame creates very durable and strong drawer

Separators allow for making compartments for organization

Ergonomic pull handle

Full extension drawer slides allow for full access to contents to drawer

## #850-1349 Angled Bottom Drawer



## #850-1359 Standard Drawer



## Pharmacy Module | #850-XXXX Accessory Modules

Image shown with

- (1) Starter module,
- (2) Add-on modules,
- (3) angled bottom pill/bottle drawers,
- (2) sliding printer shelves and
- (3) sectioned sliding drawers



FIXTURE



POWER



PROTECT



FIXTURE

## #850-0222 Printer Shelf

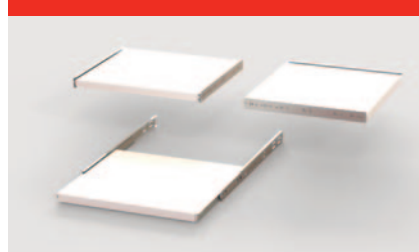

16GA steel frame creates very durable and strong drawer

Full extension drawer slides allow for full access to contents to drawer

Boston Group

**Corporate Headquarters** 3 Highwood West, Suite 100, Tewksbury, MA 01876 Tel. 781-395-7417 — 800-225-1633 (toll-free) — sales.us@boston-group.com

**European Headquarters** Sydneystraat 15, Rotterdam, 3047 BP, Netherlands Tel. +31 10 238 14 00 — sales.emea@boston-group.com. [www.boston-group.com](http://www.boston-group.com)

## Pharmacy Module | #850-XXXX Back Wall End Cap

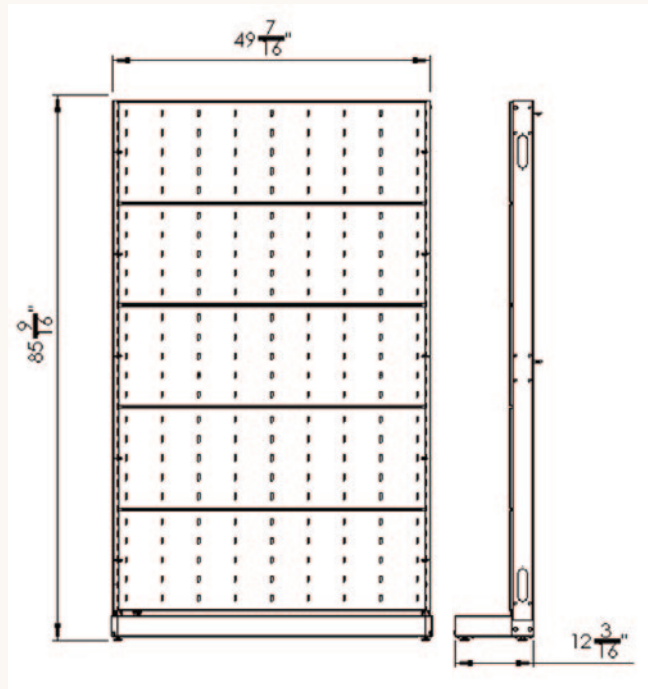

Tab and Slot shelves allow for storing products as needed

Structural back panels allow for shelving or hang bars

Tab and slot interface to uprights allows for quick assembly

Double sided

Base deck for storage options



## Pharmacy Module | #850-XXXX Back Wall End Cap

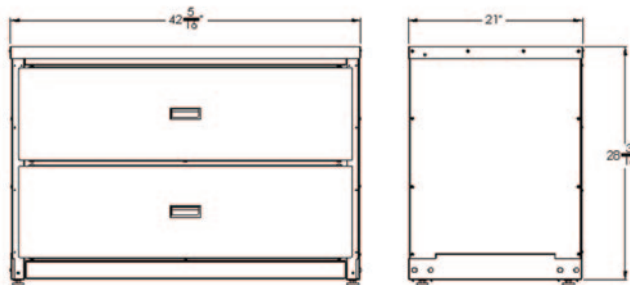

Heavy Duty drawer glides allows for 200lbs of stock storage in each drawer

Structural panels allow for stock storage in drawers and on top

Easy Pull Drawer Handles

Full extension drawer slides

Fully Adjustable leveling feet (all 4)



### Materials & Construction

- Sturdy 16GA cold rolled steel construction
- Ships to customer site partially assembled to speed site installation
- Heavy duty adjustable leveling feet accommodates uneven floors
- Our state of the art Powder Coating line provides the most durable finishes in hundreds of color options
- Adjustable leveling feet accommodates uneven floors



**Corporate Headquarters** 3 Highwood West, Suite 100, Tewksbury, MA 01876 Tel. 781-395-7417 — 800-225-1633 (toll-free) — [sales.us@boston-group.com](mailto:sales.us@boston-group.com)

**European Headquarters** Sydneystraat 15, Rotterdam, 3047 BP, Netherlands Tel. +31 10 238 14 00 — [sales.emea@boston-group.com](mailto:sales.emea@boston-group.com) [www.boston-group.com](http://www.boston-group.com)

# Pharmacy Fixture Solutions

Design & Simulation | Production & Manufacturing

## Design & Simulation

With cutting edge design and manufacturing capabilities Boston Group stays ahead with continuous investment in capabilities to deliver value driven solutions. Our advanced simulation and modeling software allow you to view your fixture design in isolation, as single unit or within the intended environment.

## Production & Manufacturing

Boston Group employs fully automated manufacturing cells that punch, bend, form and laser-cut to exact specifications, bridging concept to product release.

## Certification & Compliance

We ensure every product we make complies with strict third party national safety standards for mechanical, electrical and environmental compliance.

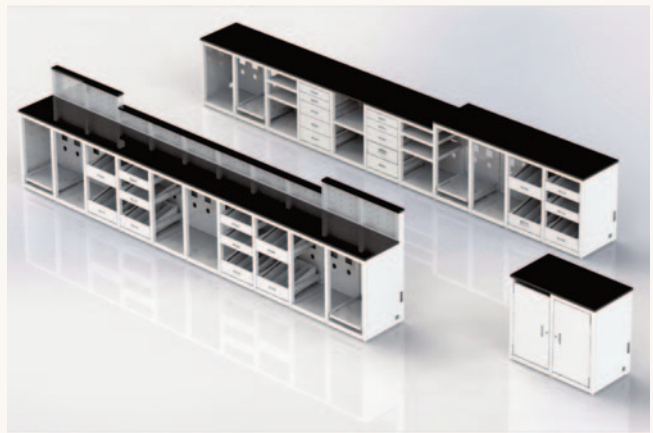
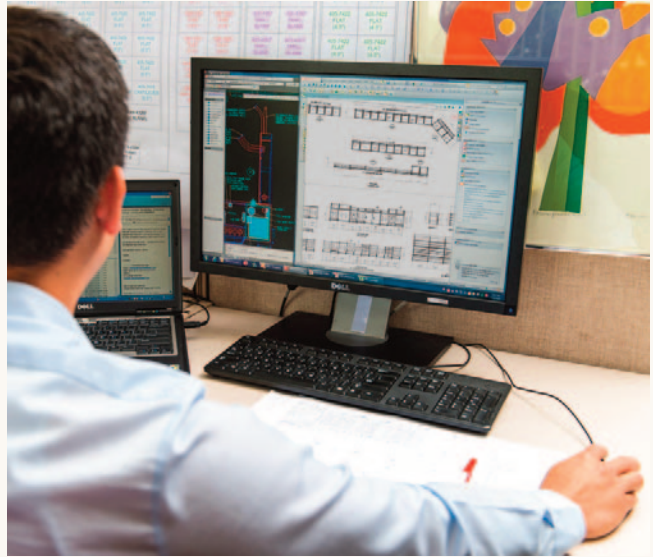

FIXTURE

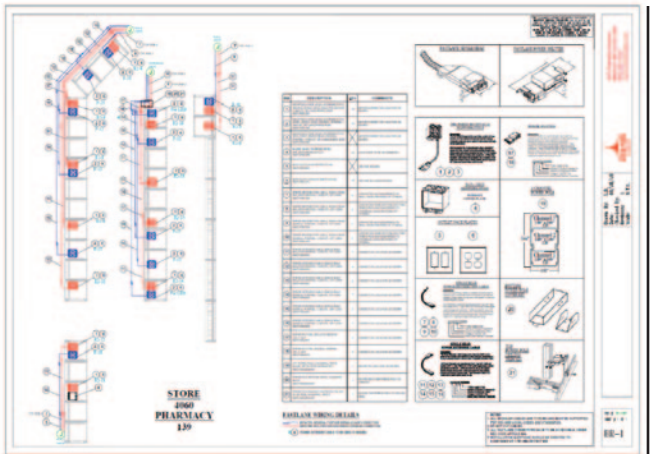
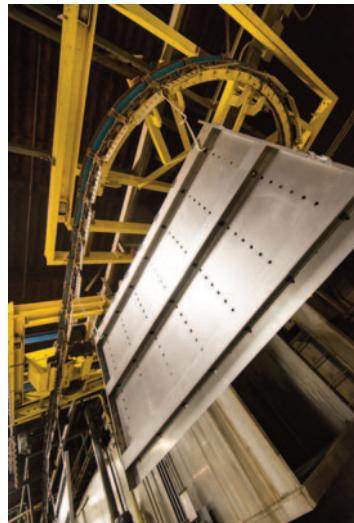

POWER



PROTECT



FIXTURE



Boston Group

# Desks

Fully customizable based on customers needs

Boston Group's line of industrial and commercial grade desk and cabinet solutions offers durable and sustainable modules that easily adapt to meet the needs of any environment. Our team works closely with you to understand your specific needs and create your ideal solution. We accomplish this through the use of existing modules, custom designs, or a combination of both. All of these products are designed and manufactured at our facilities in the U.S. to insure the highest levels of quality, accuracy, and service. Boston Group's desk and cabinet systems can incorporate FastLane™ plug and play power systems to deliver fast and seamless integration.



## Applying ingenuity around the world.

Boston Group provides total solutions to energize environments, protect assets and support unique shopping or working experience. We listen carefully, look beyond the challenge and come up with smart solutions, exploring new domains every day together with you. From initial concept to full product rollout we expertly guide the process to deliver the right solutions for your needs.



FIXTURE

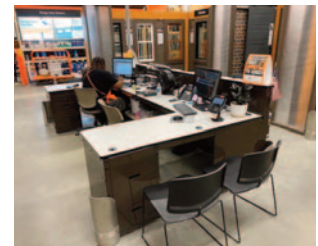

POWER



PROTECT



FIXTURE

Boston Group

Corporate Headquarters 3 Highwood West, Suite 100, Tewksbury, MA 01876 Tel. 781-395-7417 — 800-225-1633 (toll-free) — sales.us@boston-group.com

European Headquarters Sydneystraat 15, Rotterdam, 3047 BP, Netherlands Tel. +31 10 238 14 00 — sales.emea@boston-group.com. [www.boston-group.com](http://www.boston-group.com)

MADE IN THE USA • V SEPT 2025

# Desks

Fully customizable based on customers needs

## Design & Simulation

With cutting edge design and manufacturing capabilities Boston Group stays ahead with continuous investment in capabilities to deliver value driven solutions. Our advanced simulation and modeling software allow you to view your fixture design in isolation, as single unit or within the intended environment.

## Production & Manufacturing

Boston Group employs fully automated manufacturing cells that punch, bend, form and laser-cut to exact specifications, bridging concept to product release.

## Materials & Construction

- Sturdy 16GA cold rolled steel construction
- Ships to customer site partially assembled to speed site installation
- Heavy duty adjustable leveling feet accommodates uneven floors
- Our state of the art Powder Coating line provides the most durable finishes in hundreds of color options.

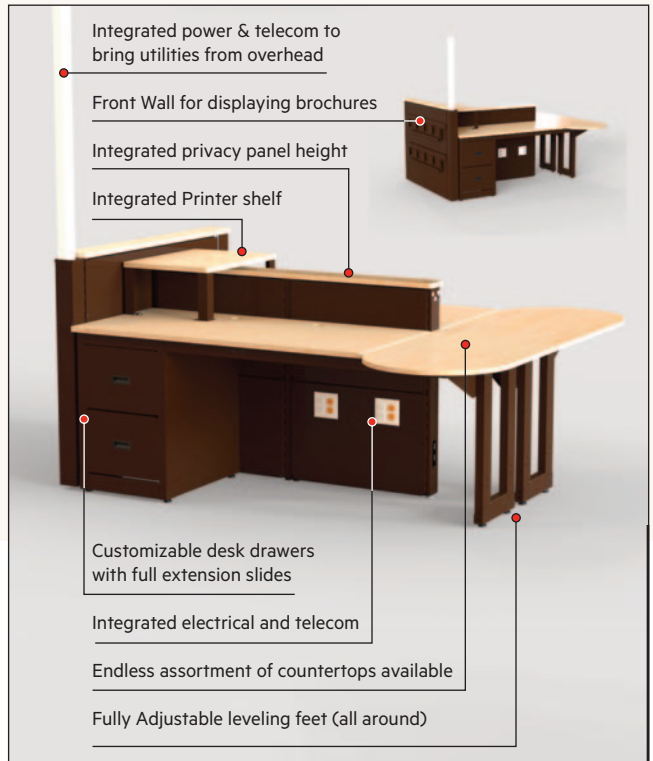

FIXTURE

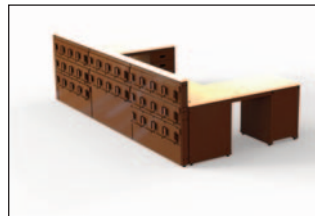

POWER



PROTECT



FIXTURE

Boston Group



# LOSS PREVENTION

Boston Group Security Systems for retailers provide several features and benefits that enhance safety, deter crime, and protect assets.

Retail theft is a major problem for businesses of all sizes. According to a July 2024 report from the Council on Criminal Justice (CCJ), shoplifting increased 24% in the first half of the year in 23 cities, even while other types of crime decreased. In response to these challenges, retailers are turning to anti-theft technology, such as merchandise display solutions without significantly compromising the customer experience.



## Applying ingenuity around the world.

Boston Group provides total solutions to energize environments, protect assets and support unique shopping or working experience. We listen carefully, look beyond the challenge and come up with smart solutions, exploring new domains every day together with you. From initial concept to full product rollout we expertly guide the process to deliver the right solutions for your needs.



PROTECT

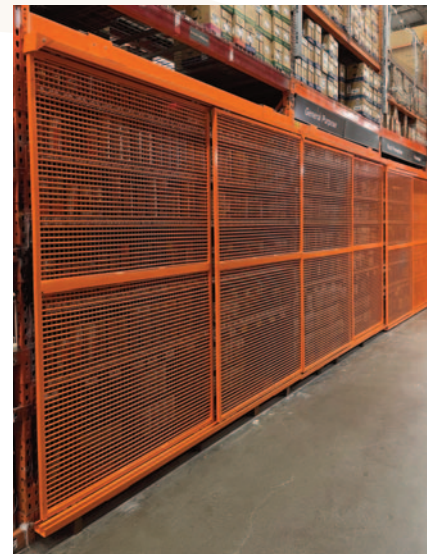

POWER



PROTECT



FIXTURE



Boston Group

Corporate Headquarters 3 Highwood West, Suite 100, Tewksbury, MA 01876 Tel. 781-395-7417 — 800-225-1633 (toll-free) — sales.us@boston-group.com

European Headquarters Sydneystraat 15, Rotterdam, 3047 BP, Netherlands Tel. +31 10 238 14 00 — sales.emea@boston-group.com. [www.boston-group.com](http://www.boston-group.com)

# SECURITY DOORS

- 3/16" steel wire grids.
  - Configurable on desired spacing.
  - Normal spacing is 2" on center.
- Frames and grids are Powder coated any desired color.
- Frames are made from 16GA cold rolled formed steel riveted as an assembly.
- Frames utilize smooth gliding steel roller assemblies each rated for supporting 50lbs each (100 total pounds per door).
  - Rollers are not powder coated.
- Locking clasps and brackets are available as desired.
- Outer door stops are part of the support frames to eliminate overtravel of doors when sliding.
- Top and bottom Unistrut support rails are durable and rugged to allow full structural support of doors to racking without flexing.
- Doors can be made in full height, half height or desired height as needed.
- Doors can be made as single bypassing, or multiple indexing as desired.

## Sliding Bypass Security Door - Full Rack Height

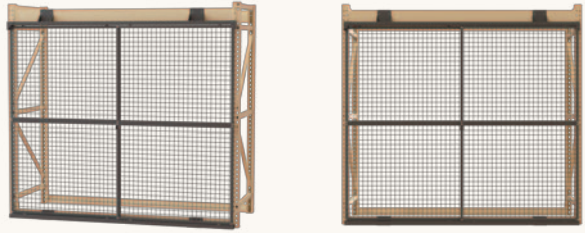

## Sliding Bypass Security Door - Half Rack Height



## Hinged Security Door - Full Rack Height

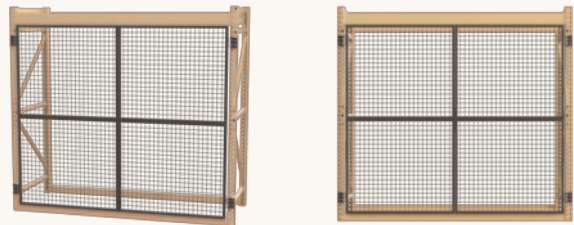

## Hinged Security Door - Half Rack Height End Cap



## Hinged Security Door - Half Rack Height



PROTECT



POWER



PROTECT



FIXTURE

Boston Group

**Corporate Headquarters** 3 Highwood West, Suite 100, Tewksbury, MA 01876 Tel. 781-395-7417 — 800-225-1633 (toll-free) — sales.us@boston-group.com

**European Headquarters** Sydneystraat 15, Rotterdam, 3047 BP, Netherlands Tel. +31 10 238 14 00 — sales.emea@boston-group.com. [www.boston-group.com](http://www.boston-group.com)

## Gondola Racking Bypassing Security Doors – Multiple Bays

# GONDOLA DOORS

- Frames are made from 16GA cold rolled formed steel riveted as an assembly.
- Doors can be configured with wire grids or lexan/polycarbonate fillers.
- Gondola assemblies can support single bay or multiple bay configurations.
- Frames are designed to fit over existing installations.
- Doors are supported with a sub assembly frame to provide maximum structural support.
- Frames utilize smooth gliding steel roller assemblies each rated for supporting 50lbs each (100 total pounds per door).  
— Rollers are not powder coated.
- Locking clasps and brackets are available as desired.
- Outer door stops are part of the support frames to eliminate overtravel of doors when sliding.
- Top and bottom Unistrut support rails are durable and rugged to allow full structural support of doors to racking without flexing.
- Doors can be made in full height, half height or desired height as needed.
- Doors can be made as single bypassing, or multiple indexing as desired.



## Gondola Racking Bypassing Security Doors – Single Bay



## Exterior Security Cages

# EXTERIOR SECURITY CAGES

- Ideal for protecting merchandise, product totes, propane tanks and more.
- 1" SQR 16GA Tubular Frame Construction
- Powder coated to resist corrosion.
- Tamper resistant hardware to minimize theft
- Expanded Metal for maximum visibility but providing security
- Easily assembled with connection hardware accessible on interior



# LOSS PREVENTION

Boston Group Security Systems for retailers provide several features and benefits that enhance safety, deter crime, and protect assets.

Here are some key features and benefits:

## Features:

### Robust Construction

- Made from durable and sustainable materials; steel, aluminum, and plexiglass.
- Optional multi-point locking systems for added security.

### Impact Resistance

- Built to resist and deter forced entry attempts.

### Visibility

- Incorporate clear or translucent materials for product visibility without compromising security.

### Customization

- Can be tailored to fit specific sizes and aesthetic requirements.
- Options available for branding and matching store design standards.



## Benefits:

### Enhanced Security:

- Deters theft, vandalism, and unauthorized access.
- Protects valuable merchandise and store assets.

### Safety for Staff and Customers:

- Provides a secure environment, reducing the risk of harm during criminal incidents.
- Peace of mind for employees and customers.

### Loss Prevention:

- Reduces the risk of inventory shrinkage due to theft.
- Potentially lower insurance premiums due to improved security measures.

### Compliance:

- Meets legal and insurance requirements for retail security.
- Adherence to fire and safety regulations.

### Deterrence:

- Visible security measures discourage potential criminals from targeting the store.
- Enhanced reputation as a safe and secure retailer.

### Operational Efficiency:

- Reduces the need for additional security personnel.
- Streamlines access for authorized personnel through advanced locking and access systems.



PROTECT

By investing in Boston Group security gates, retailers can significantly enhance their overall security posture, protect their investments, and provide a safer shopping experience for their customers.



POWER



PROTECT



FIXTURE

Boston Group



**Corporate Headquarters** 3 Highwood West, Suite 100, Tewksbury, MA 01876 Tel. 781-395-7417 — 800-225-1633 (toll-free) — sales.us@boston-group.com

**European Headquarters** Sydneystraat 15, Rotterdam, 3047 BP, Netherlands Tel. +31 10 238 14 00 — sales.emea@boston-group.com. [www.boston-group.com](http://www.boston-group.com)

# Boston Carts

Customizable, Durable and Versatile

The Boston Cart is a robust line of durable, versatile carts that hold, move and secure an array of items for multiple environments. Domestically sourced materials and made in the US robust construction. Available in your choice of colors and configurations with multiple security lock options.



## Applying ingenuity around the world.

Boston Group provides total solutions to energize environments, protect assets and support unique shopping or working experience. We listen carefully, look beyond the challenge and come up with smart solutions, exploring new domains every day together with you. From initial concept to full product rollout we expertly guide the process to deliver the right solutions for your needs.



FIXTURE



POWER



PROTECT



FIXTURE

Boston Group

Corporate Headquarters 3 Highwood West, Suite 100, Tewksbury, MA 01876 Tel. 781-395-7417 — 800-225-1633 (toll-free) — sales.us@boston-group.com

European Headquarters Sydneystraat 15, Rotterdam, 3047 BP, Netherlands Tel. +31 10 238 14 00 — sales.emea@boston-group.com. [www.boston-group.com](http://www.boston-group.com)

MADE IN THE USA • V SEPT 2025

# Boston Carts

Customizable, Durable and Versatile

## Features

- Heavy Duty 13GA Steel
- Available in Cold Rolled Stainless and Galvanized Steel
- Powder Coated
- Zinc Plated Fasteners
- Durable Casters
- Swivel / Locking Casters
- Fixed Casters
- Tray Top or Smooth Top
- Adjustable/Removeable Shelf
- Ships Assembled or Unassembled
- Security Locks

## Usage

- Warehouses / DC's
- Manufacturing & Facilities
- Retail Environments
- Commercial Environments
- Education
- Maintenance
- Indoor / Outdoor
- Fulfillment Centers



### Customized Example: Security Cart for Voting Ballots

Customer required a security cart with a locking door, retractable push handle, adjustable shelves, side folding doors and view panels.



FIXTURE

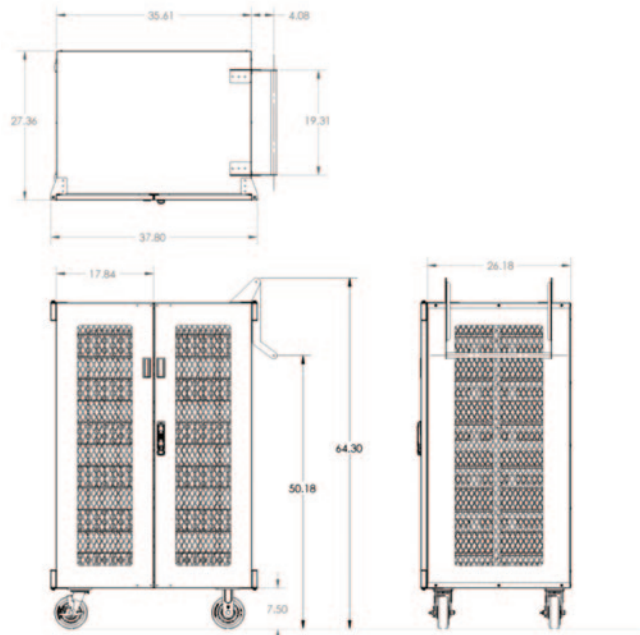

POWER



PROTECT



FIXTURE

Boston Group



# VersaPanel®

Flexible, Durable, Certified

Boston's VersaPanel® is a versatile merchandising system that powers and displays lighting fixtures. Available in a variety of powder coated finishes, supporting power access every 1.97"/ 5 cm vertically. Standard and custom spacings available horizontally.



## Applying ingenuity around the world.

Boston Group provides total solutions to energize environments, protect assets and support unique shopping or working experience. We listen carefully, look beyond the challenge and come up with smart solutions, exploring new domains every day together with you. From initial concept to full product rollout we expertly guide the process to deliver the right solutions for your needs.



POWER



POWER



PROTECT



FIXTURE

Boston Group

**Corporate Headquarters** 3 Highwood West, Suite 100, Tewksbury, MA 01876 Tel. 781-395-7417 — 800-225-1633 (toll-free) — [sales.us@boston-group.com](mailto:sales.us@boston-group.com)

**European Headquarters** Sydneystraat 15, Rotterdam, 3047 BP, Netherlands Tel. +31 10 238 14 00 — [sales.emea@boston-group.com](mailto:sales.emea@boston-group.com). [www.boston-group.com](http://www.boston-group.com)

MADE IN THE USA • V SEPT 2025

# VersaPanel®

Flexible, Durable, Certified

- **Easy and fast installation**
- **UL listed and Certified**
- **Flexible**
- **Customizable**
- **Aesthetic to meet your needs**

- Merchandise more in less space.
- Merchandise with graphic communications.
- Create a unique selling environment.
- Wall, racking & gondola mounting options.
- Wide range of standard accessories.
- Integrate shelving, hooks, graphics and more to display product in their best light.

- With a narrow profile, it's perfect for fitting into your design schemes.
- Over 150 powder coat color options.
- Multi-panel assemblies can be fed by a single branch circuit.
- Decrease installation downtime for re-merchandising.
- Certified for use with Boston Group's FastLane® modular wiring systems.
- Reduce installation time and increase safety and reliability.

## Benefits

- Ships pre-configured, pre-wired and pre-tested.
- Safety agency approved and certified.
- Meets all applicable codes and certifications.
- Less wiring and field terminations.



POWER



POWER



PROTECT



FIXTURE

Boston Group



**Corporate Headquarters** 3 Highwood West, Suite 100, Tewksbury, MA 01876 Tel. 781-395-7417 — 800-225-1633 (toll-free) — sales.us@boston-group.com

**European Headquarters** Sydneystraat 15, Rotterdam, 3047 BP, Netherlands Tel. +31 10 238 14 00 — sales.emea@boston-group.com. [www.boston-group.com](http://www.boston-group.com)

# VersaPanel®

## Universal Adaptor

The transparent, VersaPanel® Universal Adapter blends into the display, so emphasis is on the showcased product. The adapter secures fixtures to the VersaPanel® weighing up to 25 kg! Assembly and installation takes about 1 to 5 minutes, minimizing the amount of time required for merchandising updates.

- Engineered for quick connection of fixtures to the VersaPanel®.
- Blends into the display, so emphasis is on the showcased product.
- Most often requires no tools or hardware to install.
- Certified safe: KEMA, GOST, CE, cUL, UL listed.
- For aesthetic purposes, the Mini-Adapter does not contain the metal reinforcement plate.

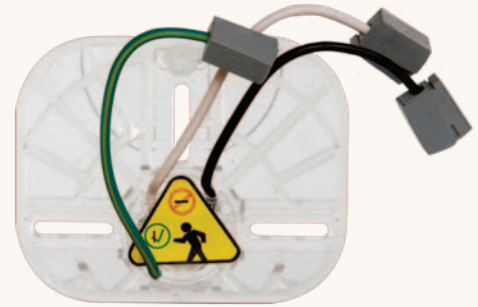
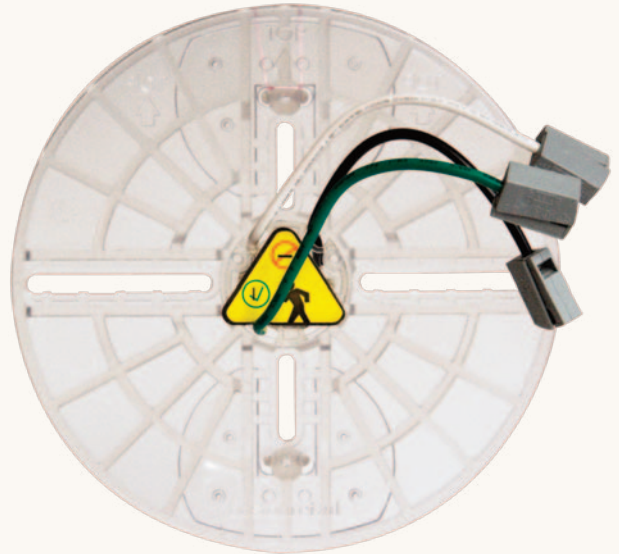

**Corporate Headquarters** 3 Highwood West, Suite 100, Tewksbury, MA 01876 Tel. 781-395-7417 — 800-225-1633 (toll-free) — [sales.us@boston-group.com](mailto:sales.us@boston-group.com)

**European Headquarters** Sydneystraat 15, Rotterdam, 3047 BP, Netherlands Tel. +31 10 238 14 00 — [sales.emea@boston-group.com](mailto:sales.emea@boston-group.com) [www.boston-group.com](http://www.boston-group.com)

# VersaPanel®

## VersaPanel® Accessories

For all applications and different lighting categories, the Boston VersaPanel® system provides you with a wide range of accessories.

The pictures below can only show a part of the accessory range. More accessories can be offered upon request.



Table Lamp Brackets;  
Transparent 8mm Part



Post Lamp Bracket; Wood



Transparent Arm for  
Pendent Lights



Spike Light Bracket; Metal

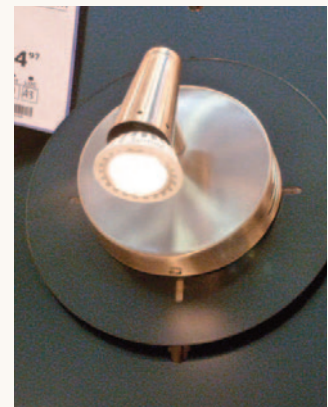

Adapter Cover Plate; Metal



POWER



Universal Metal Bracket  
for Pendent Lights and  
Desk Lights



Universal Wood Brackets for  
Desk Lights ...



... and Recessed Lights



POWER



PROTECT



FIXTURE

Boston Group



# PowerTrack™ Pods

Overhead Rack/Bay, Light & Fan Clouds

**Boston Retail's PowerTrack™ Pods are a versatile resource for attractively displaying ceiling light fixtures. They are constructed with PowerTrack™ and filler panels that fit easily overhead in warehouse racking. PowerTrack™ is the pre-fabricated, factory built core electrical component. PowerTrack's consistent high quality standards allow for speedy installation for multi-display and store roll-outs. Combine PowerTrack™ with a large choice of filler panels, fixture hangers, color and texture options to create a unique display that complements your merchandising scheme.**



**Applying ingenuity around the world.**

Boston Group provides total solutions to energize environments, protect assets and support unique shopping or working experience. We listen carefully, look beyond the challenge and come up with smart solutions, exploring new domains every day together with you. From initial concept to full product rollout we expertly guide the process to deliver the right solutions for your needs.



POWER



POWER



PROTECT



FIXTURE



Boston Group

# PowerTrack™ Pods

Overhead Rack/Bay, Light & Fan Clouds

## Features and Benefits

- 16 gauge steel frame construction.
- 12" and 18" on center receptacle spacing for maximum merchandising density.
- 120V, 20A rated assemblies.
- Over 150 powder coated color choices.
- Combine different filler panel options to blend with your merchandising scheme.
- Assembly options include up to 8 tracks.

## Versatile for any Display Need

- Our Track Clouds are stick built. Meaning they can be made to whatever size you require by putting together the track and the various hardware parts.
- Boston Group can supply the support beam structure as well as the cable or you can use your own.
- The wiring for the PowerTrack™ is on top of the track. There is a wiring raceway.
- The track also has outlets spaced either 12" or 18" on center.
- Attach the light fixture or ceiling fan to our Fixture Hanger and that allows you to attach the light or fan anywhere along the track. The Fixture Hanger has a cord set attached. Plug the cord set into the outlet on the track and it's powered up.



POWER



POWER



PROTECT



FIXTURE

Boston Group

**Corporate Headquarters** 3 Highwood West, Suite 100, Tewksbury, MA 01876 Tel. 781-395-7417 — 800-225-1633 (toll-free) — [sales.us@boston-group.com](mailto:sales.us@boston-group.com)

**European Headquarters** Sydneystraat 15, Rotterdam, 3047 BP, Netherlands Tel. +31 10 238 14 00 — [sales.emea@boston-group.com](mailto:sales.emea@boston-group.com) [www.boston-group.com](http://www.boston-group.com) •

### Very Safe and Attractive

- Our PowerTrack™ system has no exposed wires.
- Using our Fixture Hangers is easy. You can then attach the light fixture or ceiling fan anywhere along the track.
- You can add items to dress up your track cloud such as a steel frame around the perimeter of the track cloud or use acrylic or steel panels in between the rows of track.
- You can also do an “open” look where you leave the space between the rows of track open.
- Boston Group has in house powder coating capabilities so we can offer our PowerTrack™ in a wide variety of colors. White, black and beige are the most popular.



### An Organized Method of Displaying

#### Hanging Lights and Ceiling Fans

- Using our PowerTrack™ System keeps your merchandise displayed in a neat and organized fashion.
- As a result, you should realize more sales.
- Because of the flexibility of the system, you can space the rows of track as close or as far apart as required.
- With your lights and fans attached to our Fixture Hangers you have the flexibility to place the product anywhere along the track where you want it.



# PowerTrack™ Pods

Overhead Rack/Bay, Light & Fan Clouds

**Application:**

Rack/Bay Mounted, Overhead

**Standard rack widths:**

87" (2 x 43" displays)

97" and 99" (2 x 48" displays)

144" (3 x 48" displays)

**Standard bay depths:**

36", 42" and 48"

Custom quoting upon request.

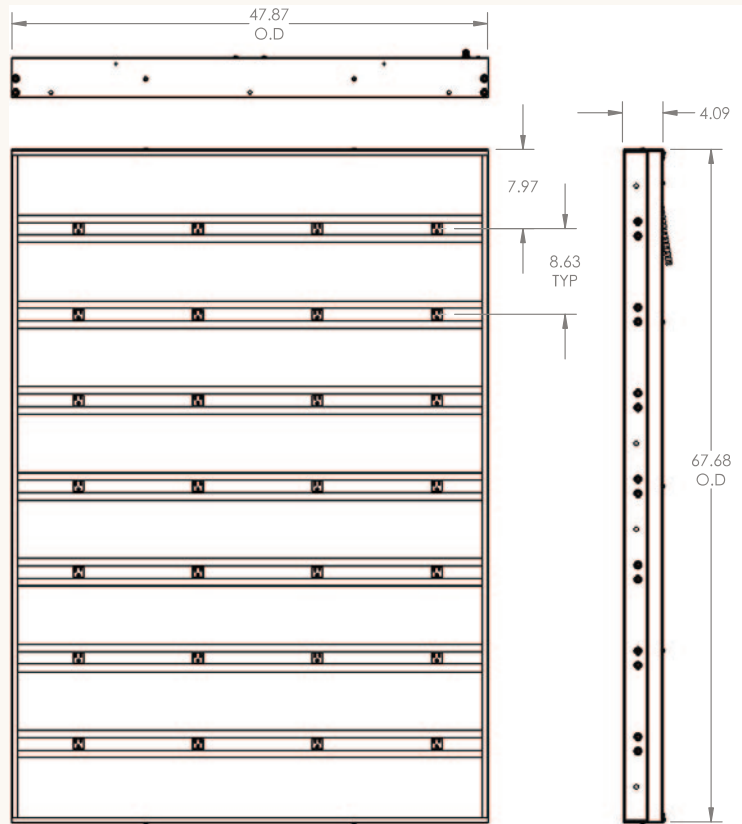

POWER

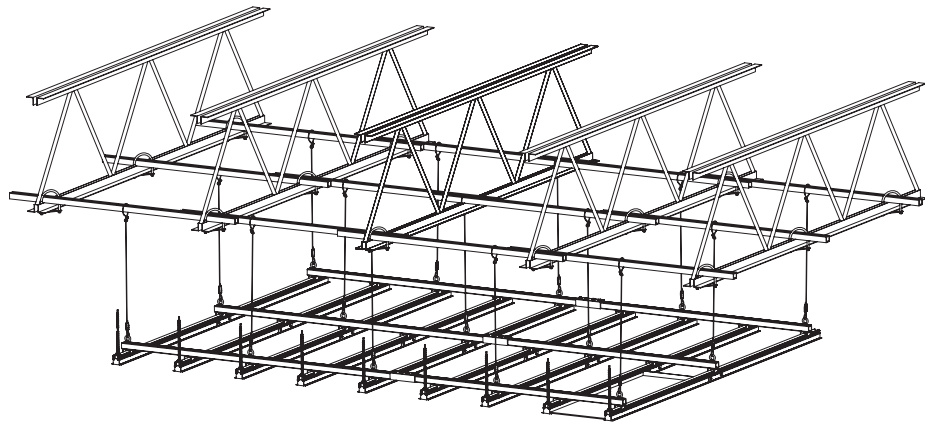

POWER



PROTECT



FIXTURE

**Examples of standard PowerTrack Pods**

Stick-built designs utilizing steel strut and Boston PowerTrack to fit your display area.



Boston Group

**Corporate Headquarters** 3 Highwood West, Suite 100, Tewksbury, MA 01876 Tel. 781-395-7417 — 800-225-1633 (toll-free) — sales.us@boston-group.com

**European Headquarters** Sydneystraat 15, Rotterdam, 3047 BP, Netherlands Tel. +31 10 238 14 00 — sales.emea@boston-group.com. [www.boston-group.com](http://www.boston-group.com)

# VersaTrack

Gondola or warehouse racking mounted display.



## Applying ingenuity around the world.

Boston Group provides total solutions to energize environments, protect assets and support unique shopping or working experience. We listen carefully, look beyond the challenge and come up with smart solutions, exploring new domains every day together with you. From initial concept to full product rollout we expertly guide the process to deliver the right solutions for your needs.



FIXTURE

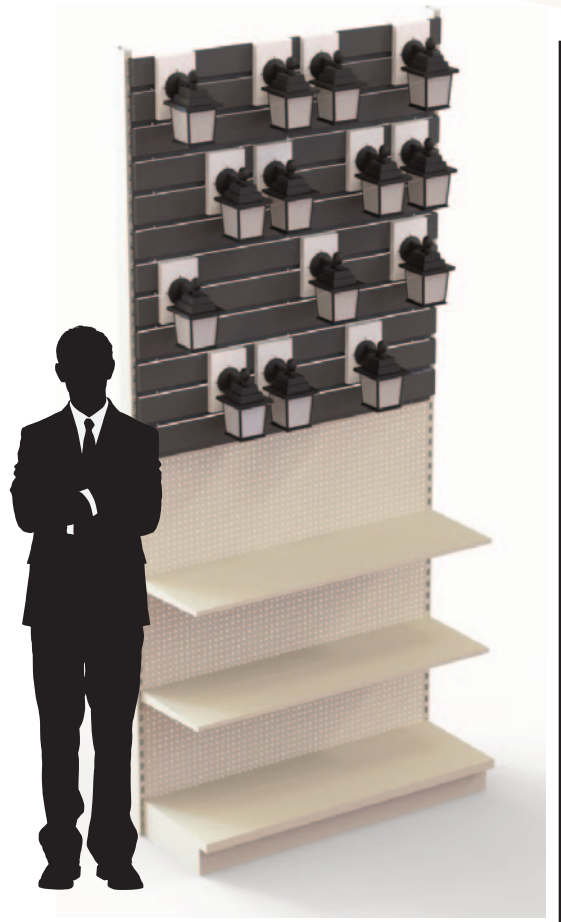

POWER



PROTECT



FIXTURE

Boston Group

**Corporate Headquarters** 3 Highwood West, Suite 100, Tewksbury, MA 01876 Tel. 781-395-7417 — 800-225-1633 (toll-free) — [sales.us@boston-group.com](mailto:sales.us@boston-group.com)

**European Headquarters** Sydneystraat 15, Rotterdam, 3047 BP, Netherlands Tel. +31 10 238 14 00 — [sales.emea@boston-group.com](mailto:sales.emea@boston-group.com) [www.boston-group.com](http://www.boston-group.com)

MADE IN THE USA • V SEPT 2025

# VersaTrack

Gondola or warehouse racking mounted display.

**Features:**

- Track construction allows variable display height
- Simple Plug n' Play design
- Durable construction with sustainable materials
- Can be powder coated in any color
- 125V/60hz/15A/1500W per assembled panels. Additional power inserts can be added as needed.
- Weight load capacity of 45lbs per single slat panel
- Can install in all racking and shelving manufacturers

**Benefits:**

- Unlimited and flexible merchandising options
- Easy showcasing of powered fixtures
- Economical and can be recycled
- Aesthetic and can match your branding
- Simple, safe power connections
- Strong and suited to hold almost any fixture type
- All components designed and manufactured by Boston Group and trusted partners

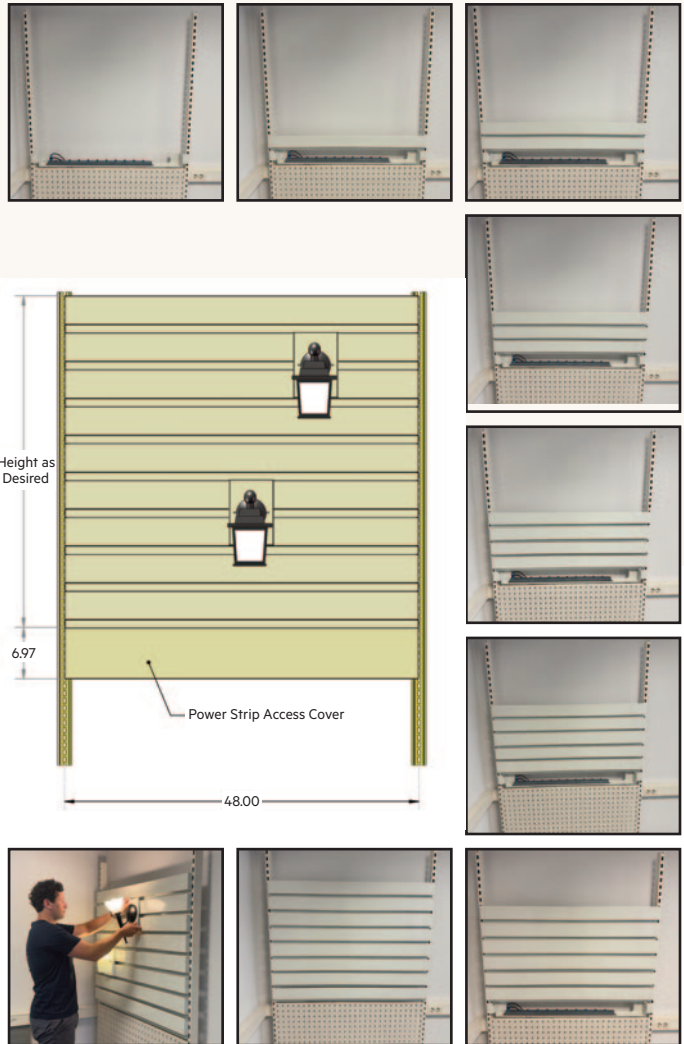

**FIXTURE**

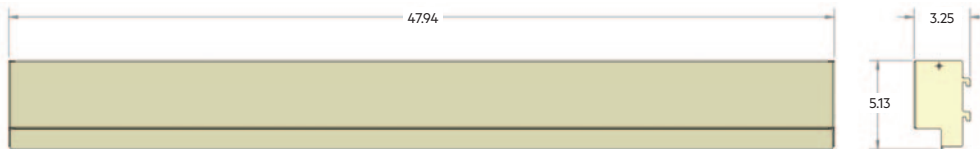

**Specs:**

- 15lbs per Fixture Hanger/Adapter
- 125V/60hz/3.7A/370W per Fixture Hanger/Adapter or 220-240V/50hz/1.5A/345W per panel

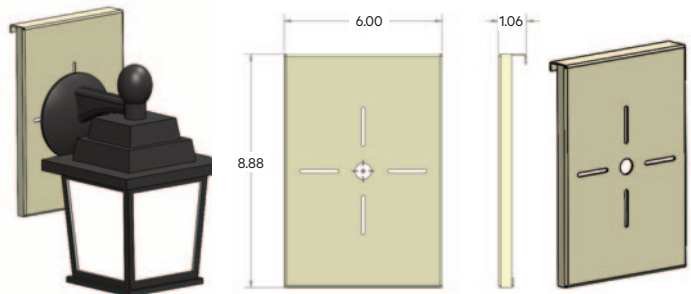

**VersaTrack Adapters**



**VersaTrack Power Strip**  
Multi-connector Power Strip



POWER



PROTECT



**FIXTURE**

Boston Group

# PowerTrack™ Fixture Hangers

Secures the fixture to Boston PowerTrack™

**Boston PowerTrack Fixture Hangers used in a vertical application require an 'Anti-Slip Clip' and have a weight capacity of 15 lbs. Consult customer service for part numbers.**



## Applying ingenuity around the world.

Boston Group provides total solutions to energize environments, protect assets and support unique shopping or working experience. We listen carefully, look beyond the challenge and come up with smart solutions, exploring new domains every day together with you. From initial concept to full product rollout we expertly guide the process to deliver the right solutions for your needs.



POWER



Pull Switch



POWER



PROTECT



FIXTURE

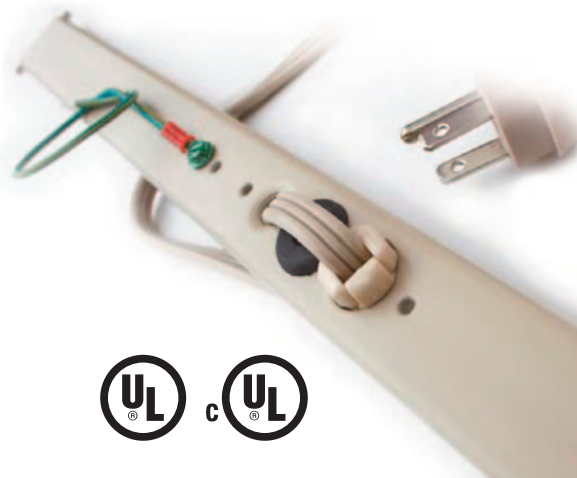

Boston Group

**Corporate Headquarters** 3 Highwood West, Suite 100, Tewksbury, MA 01876 Tel. 781-395-7417 — 800-225-1633 (toll-free) — [sales.us@boston-group.com](mailto:sales.us@boston-group.com)

**European Headquarters** Sydneystraat 15, Rotterdam, 3047 BP, Netherlands Tel. +31 10 238 14 00 — [sales.emea@boston-group.com](mailto:sales.emea@boston-group.com) • [www.boston-group.com](http://www.boston-group.com)

MADE IN THE USA • V SEPT 2025

# PowerTrack™ Fixture Hangers

Secures the fixture to Boston PowerTrack™

\* Boston PowerTrack Fixture Hangers used in a vertical application require an 'Anti-Slip Clip' and have a weight capacity of 15 lbs. Consult customer service for part numbers.



## Assembly and Installation

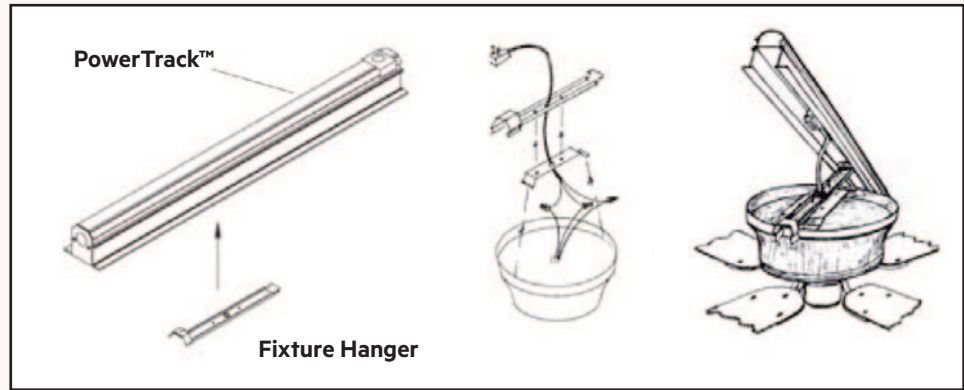

POWER

### Range of Availability

Length	Weight Capacity	Max. Light/Fan Canopy Dia.	Part #	w/pull switch Part#
10.5"	100 lb	6"	FHG105BL-XXX	FHG105BLS-XXX
16"	75 lb	13"	FHG16BL-XXX	FHG16BLS-XXX
21"	50 lb	16"	FHG21BL-XXX	FHG21BLS-XXX

Standard Overhead\*

-XXX Denotes that a color tab must be added to the part number at the time of ordering.

10.5" Unswitched Fixture Hanger in semi-gloss white (also available in 16" & 21" lengths)



10.5" Switched Fixture Hanger in semi-gloss black (also available in 16" & 21" lengths)



POWER



PROTECT



FIXTURE

### Standard Colors

Finish	Black	White
Semi-Gloss	010	009

-xxx denotes standard color option included at no charge.



Boston Group

# Gondola Mounted Track Arm Displayer

Allows to display light fixtures and ceiling fans easily and economically.



## Applying ingenuity around the world.

Boston Group provides total solutions to energize environments, protect assets and support unique shopping or working experience. We listen carefully, look beyond the challenge and come up with smart solutions, exploring new domains every day together with you. From initial concept to full product rollout we expertly guide the process to deliver the right solutions for your needs.



FIXTURE

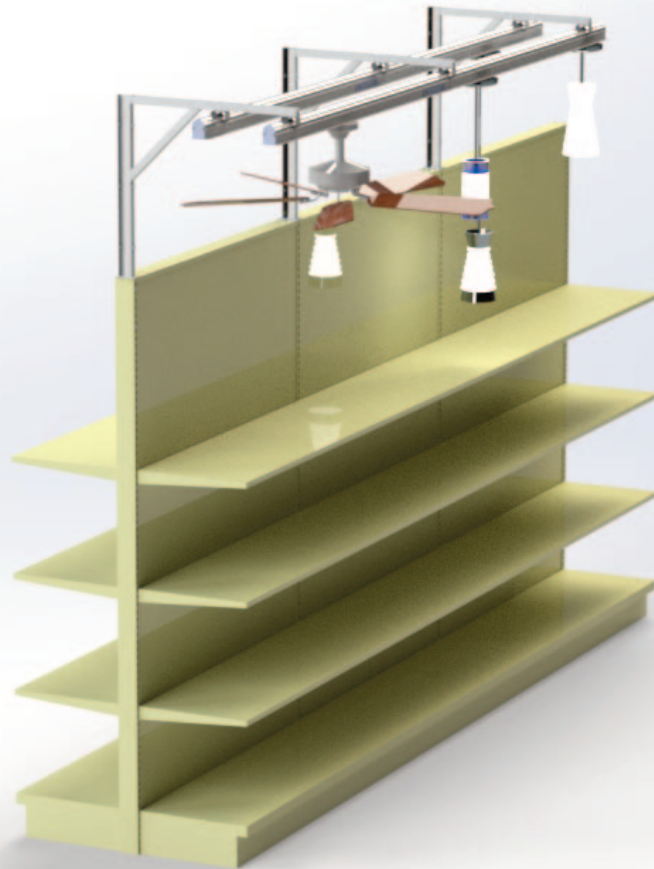

POWER



PROTECT



FIXTURE

Boston Group

**Corporate Headquarters** 3 Highwood West, Suite 100, Tewksbury, MA 01876 Tel. 781-395-7417 — 800-225-1633 (toll-free) — [sales.us@boston-group.com](mailto:sales.us@boston-group.com)

**European Headquarters** Sydneystraat 15, Rotterdam, 3047 BP, Netherlands Tel. +31 10 238 14 00 — [sales.emea@boston-group.com](mailto:sales.emea@boston-group.com) [www.boston-group.com](http://www.boston-group.com)

# Gondola Mounted Track Arm Displayer

- Easily inserts into top of gondola uprights
- Can run as long as needed
- Made of heavy duty 13 ga cold rolled steel
- Can attach up to 2 lengths of our PowerTrack
- Ideal if you only want to display a few fixtures
- Can display on 2 sides

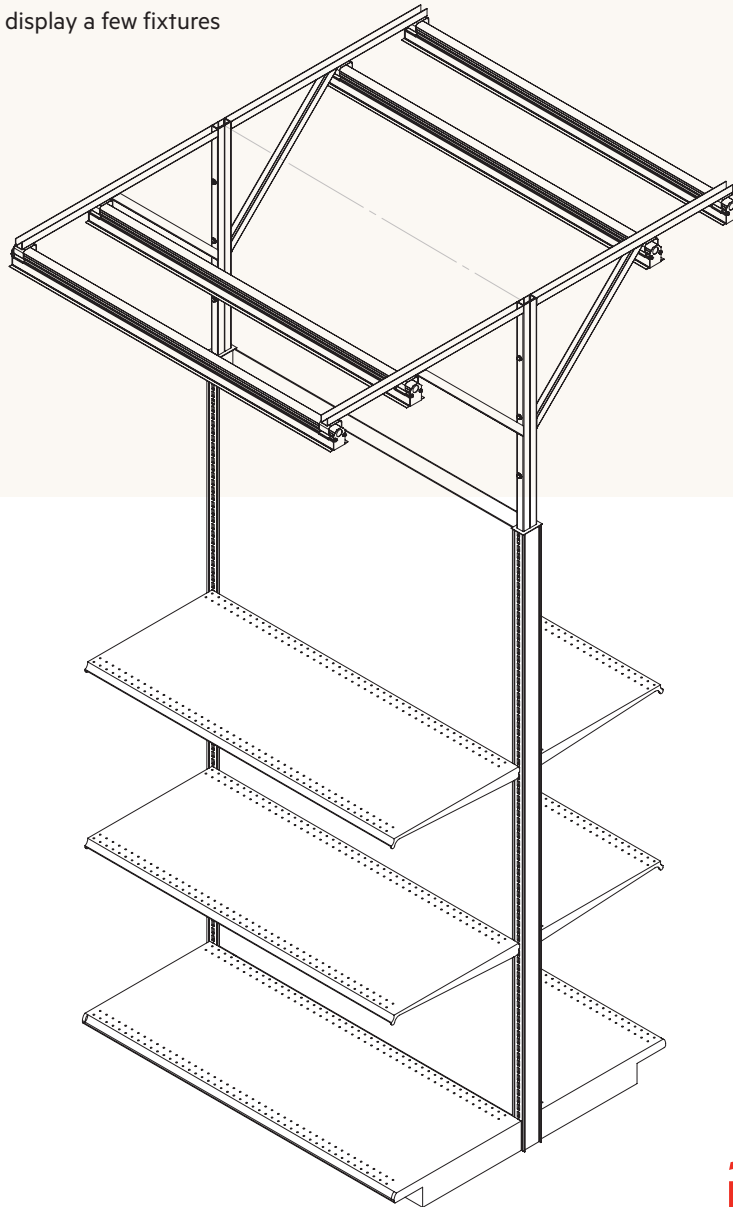
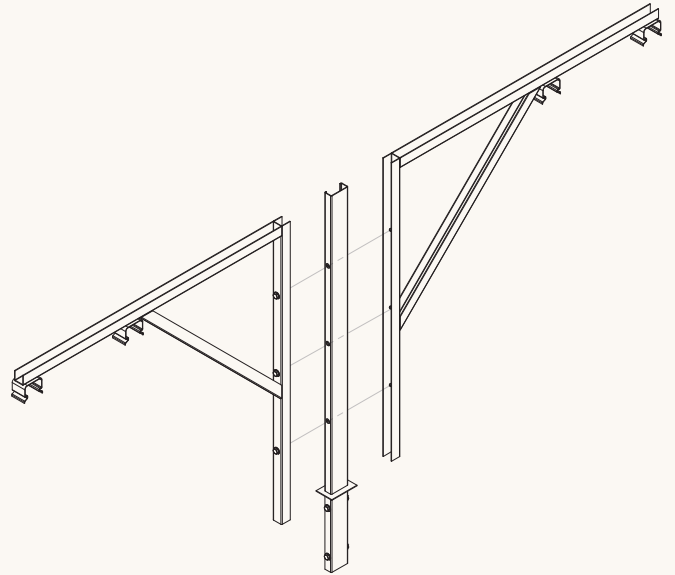

PROTECT



POWER



PROTECT



FIXTURE



Boston Group

**Corporate Headquarters** 3 Highwood West, Suite 100, Tewksbury, MA 01876 Tel. 781-395-7417 — 800-225-1633 (toll-free) — sales.us@boston-group.com

**European Headquarters** Sydneystraat 15, Rotterdam, 3047 BP, Netherlands Tel. +31 10 238 14 00 — sales.emea@boston-group.com. [www.boston-group.com](http://www.boston-group.com)

Embrace impact everyday

# Protect

You want to protect your assets and your customers. Our wide range of impact protection products and total solutions allow you to do so, time and time again.



# Ingenuity applied means enabling you to achieve your goals

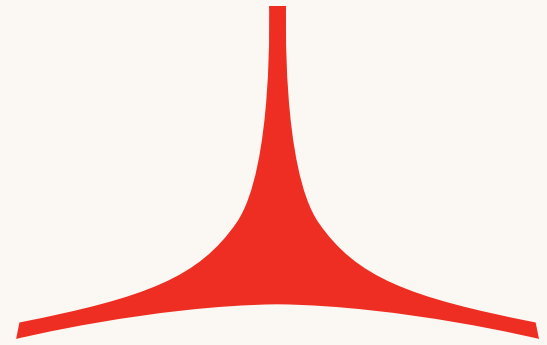

## Protection Applied at Major Food Retailer

Complete impact protection & provided directly from the manufacturer

Our client is a growing regional supermarket chain in the southwest of the United States that began serving families back in 1964 with its first store in Olton Texas. Since then, their philosophy has been to take care of the community, their employees and their families - a philosophy we can relate to.

**This Major Food Retailer** was looking for smart solutions to protect the assets of their stores from damage caused by carts and cleaners and to improve the shopping experience of their customers. They approached us because of our extensive experience in bumpers. But even more important, they wanted to deal directly with the manufacturer instead of a reseller because of better quality, better service and more savings.

**First we surveyed** the store environment to ensure correct coverage and then developed the right logistic and support plan to help them achieve their goals. After all, impact protection is all about the details.

**Then we prescribed** the right type of protection, which was a combination of bumpers, rails and bollards. We provided a complete turn-key service, logistic and product solution.

**The result?** Our detailed and smart solutions were exactly what this Food Retailer was looking for. They saved more than 30% of their impact protection needs versus the alternative; it pays to work directly with the manufacturer. Simply expect quick delivery, product expertise and out-standing service. In short: real value.

**Now that's ingenuity applied.**



# Asset protection solutions

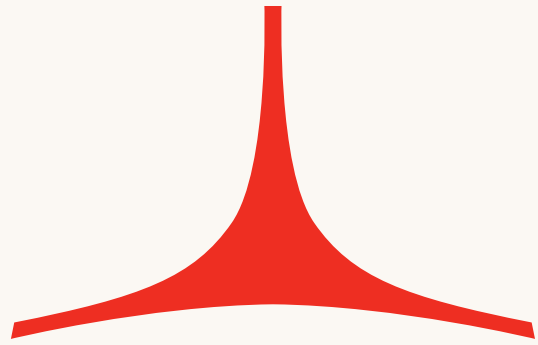

**Boston Group bundles its complete floor to ceiling line of asset protection products with outstanding customer service to exceed your protection needs for your environment. That's Ingenuity Applied.**

For over 80 years Boston Group has set the standard with its full line of bumpers, floor mounted crash rails and exterior protection solutions direct to stores, supply chain partners as well as healthcare and commercial environments.

Our expertise and experience in assessing asset protection needs and prescribing the correct type of manufactured products with top notch survey, service and deployment ensures you get the best quality product and value.

## Assessment & Survey

Our customer centric team of engineers, customer service and account managers will take the time to survey your store environment and traffic patterns to understand what type of asset protection is required.

## Planning

Upon completion of the survey, Boston Group will provide you with:

- A detailed proposal for the right type of protection and placement depending on your operational and environmental needs.
- A complete layout & BOM detailing correct type and placement of asset protection product
- A deployment plan ensuring deliverables are clear and time tables are maintained.

## Production & Manufacturing

We are the original manufacturer. In fact, we invented the category of retail asset protection with the Boston Bumper! Come visit our manufacturing facilities and see how we make our bumpers, end-caps, rails and corner guards. Our doors are always open!

## Deployment & Installation

Our expert customer service and logistics team will deploy your items when and where you need them. Boston Group's experienced staff of engineers and product management are with you every step of the way to supervise and support a seamless installation.

## Certification & Compliance

Every product we make adheres to strict third party national safety standards for mechanical, electrical and environmental compliance.

Boston Group cares about the environment. With over 10 years of being a UL Environment Certified company (the only bumper manufacturer with this certification), we are proud to have placed great emphasis on incorporating recycled material in our product design and manufacture. We are pleased we can report a 15% increase in our year over year usage of post consumer, post industrial content.



# It's all in the details

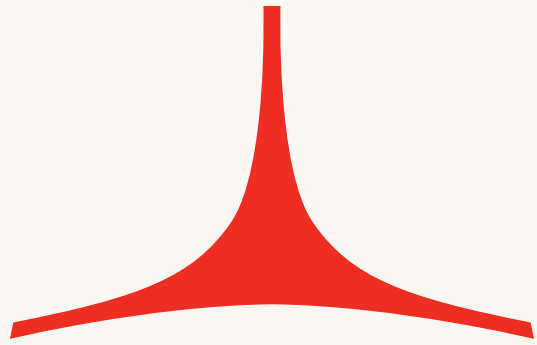

**Let our design, engineering and manufacturing experts help invigorate your environment**

Boston Group, founded in 1937, offers the very latest in design and manufacturing to turn your projects around quickly from concept to finished solutions.

## Integrated Solutions Philosophy

Boston Group designs and manufactures fixtures that bundle a variety of core materials (metal, wood, plastic, power, lighting and technology) into a modular design that allows seamless integration into any environment. Ingenuity Applied!

### **Cutting edge capabilities**

To stay competitive, Boston Group continuously invests in it's manufacturing capabilities to provide value driven solutions, quickly and efficiently.

### **Insight and thoughtfulness**

Our people make it all happen. To make a project viable, we formulate cross-functional teams comprising of account managers, designers, purchasers manufacturing engineers and customers service support.

### **Experience with energy**

The philosophy of Boston Group is to generate true value for our customers. We take time to understand your goals and objectives and apply our extensive experience to create configurable and scalable solutions for your environment.

## Challenge us...

At Boston Group, we love a good challenge. We strive to learn and push boundaries, so give us your toughest problem and we'll come up with a solution that meets your needs and budget.



# Safety Xtreme

Round and Square Bollard

Extreme Storefront Protection for safeguarding customers and property from accidental or deliberate vehicle impacts

100

Storefront crashes per day

16,000

Injured annually

2,600

Deaths every year

43%

Happen at retail and restaurant locations

Data from the  
Storefront Safety  
Council



Applying ingenuity around the world.

Boston Group provides total solutions to energize environments, protect assets and support unique shopping or working experience.

We listen carefully, look beyond the challenge and come up with smart solutions, exploring new domains every day together with you.

From initial concept to full product rollout we expertly guide the process to deliver the right solutions for your needs.



PROTECT



POWER



PROTECT



FIXTURE



Boston Group

Corporate Headquarters 3 Highwood West, Suite 100, Tewksbury, MA 01876 Tel. 781-395-7417 — 800-225-1633 (toll-free) — sales.us@boston-group.com

European Headquarters Sydneystraat 15, Rotterdam, 3047 BP, Netherlands Tel. +31 10 238 14 00 — sales.emea@boston-group.com. [www.boston-group.com](http://www.boston-group.com)

MADE IN THE USA • V SEPT 2025

# Safety Xtreme

## Round and Square Bollard

**SPEC:** 4.5" Round Safety Xtreme Bollard

**MATERIAL:** Hot Dipped Galvanized Steel

**FINISH:** Hot Dipped Galvanized Steel (Can be powder coated or covered with Stainless Steel or colored plastic bollard covers)

**HEIGHT ABOVE GRADE:** 36" in

\* **CRASH TEST RATING:** ASTM F3016 S20  
Certified to stop a 5000lb vehicle traveling at 20mph

**SPEC:** 5.5" Square Safety Xtreme Bollard

**MATERIAL:** Hot Dipped Galvanized Steel

**FINISH:** Hot Dipped Galvanized Steel (Can be powder coated or covered with Stainless Steel or colored plastic bollard covers)

**HEIGHT ABOVE GRADE:** 36" in

\* **CRASH TEST RATING:** ASTM F3016 S20  
Certified to stop a 5000lb vehicle traveling at 20mph

\* The ASTM F3016 was designed to establish a repeatable and reproducible test for assignment of uniform speed and penetration rating designations on protective devices, like a bollard, when impacted by a common vehicle weight. This certified third party testing was performed by Calspan Corp and certification letters can be supplied.

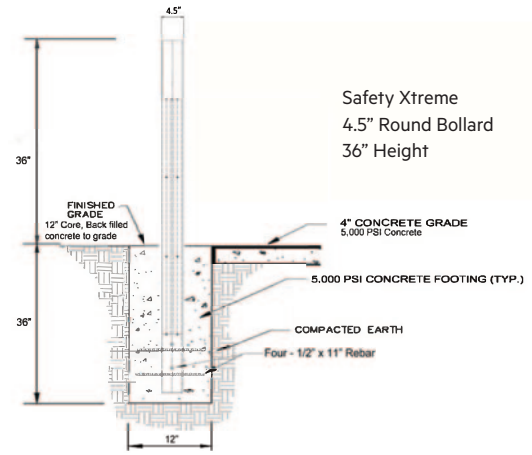

Delivered ready for easy installation without any required underground cage hardware.

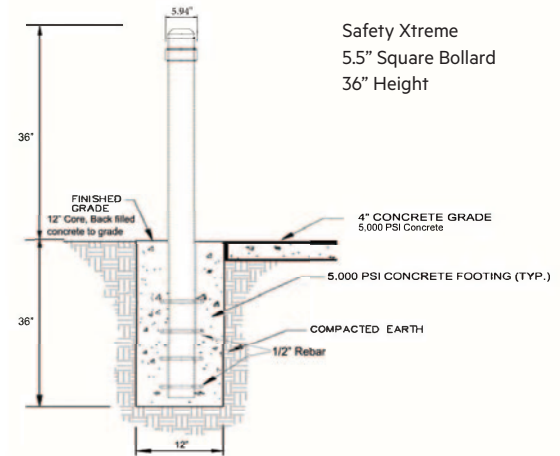

Delivered ready for easy installation without any required underground cage hardware.



PROTECT

### COMPONENT DESCRIPTION

Core Safety Xtreme Round or Square  
Cover Options HDPE Post Covers with Foam Tape (72" and can be cut down)  
(variety of colors and materials available upon request)

Change the appearance by adding a round cover to your bollard.  
Popular Cover Options - More Options Available Upon Request

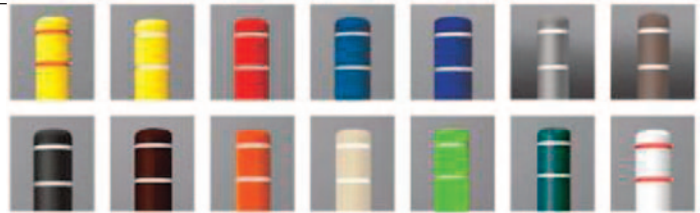

### SIGN POST ADD-ON (ADA Sign with Blue Cover)

#### COMPONENT DESCRIPTION

Sign Post Kit Safety X Bollard Sign Post Add-on  
\*Handicap Sign Not Included



POWER



PROTECT



FIXTURE



Boston Group

**Corporate Headquarters** 3 Highwood West, Suite 100, Tewksbury, MA 01876 Tel. 781-395-7417 — 800-225-1633 (toll-free) — sales.us@boston-group.com

**European Headquarters** Sydneystraat 15, Rotterdam, 3047 BP, Netherlands Tel. +31 10 238 14 00 — sales.emea@boston-group.com. [www.boston-group.com](http://www.boston-group.com)

# Safety Xtreme

## X Frame Bollard

Extreme Storefront Protection for safeguarding customers and property from accidental or deliberate vehicle impacts

100

Storefront crashes per day

16,000

Injured annually

2,600

Deaths every year

43%

Happen at retail and restaurant locations

Data from the Storefront Safety Council



Applying ingenuity around the world.

Boston Group provides total solutions to energize environments, protect assets and support unique shopping or working experience.

We listen carefully, look beyond the challenge and come up with smart solutions, exploring new domains every day together with you.

From initial concept to full product rollout we expertly guide the process to deliver the right solutions for your needs.

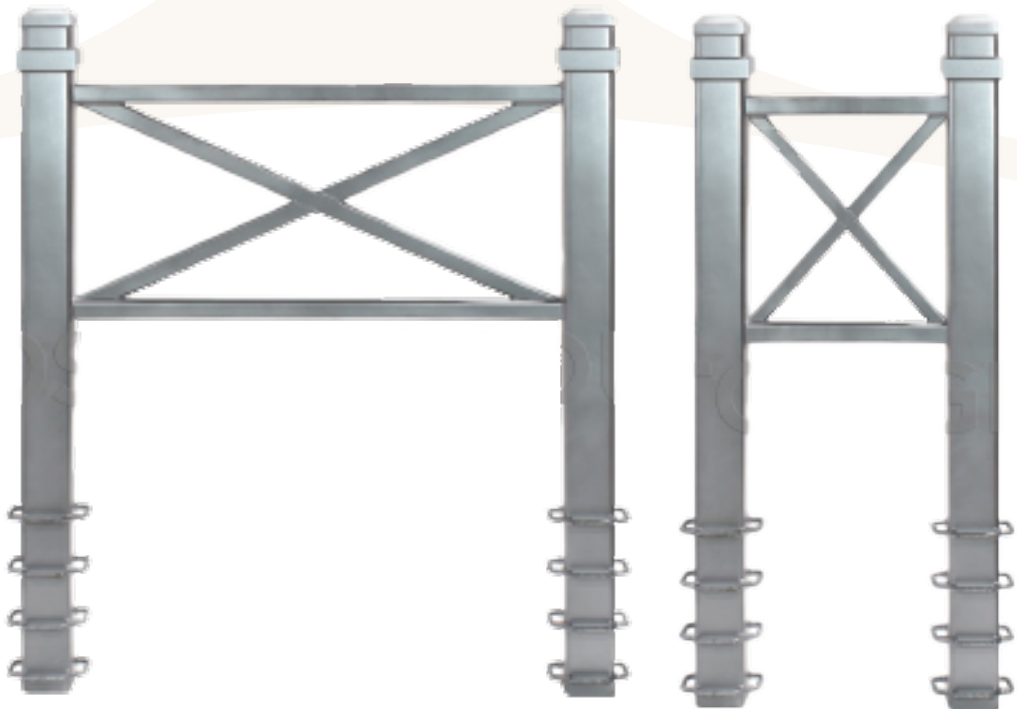

PROTECT



POWER



PROTECT



FIXTURE



Boston Group

Corporate Headquarters 3 Highwood West, Suite 100, Tewksbury, MA 01876 Tel. 781-395-7417 — 800-225-1633 (toll-free) — sales.us@boston-group.com

European Headquarters Sydneystraat 15, Rotterdam, 3047 BP, Netherlands Tel. +31 10 238 14 00 — sales.emea@boston-group.com. [www.boston-group.com](http://www.boston-group.com)

MADE IN THE USA • V SEPT 2025

# Safety Xtreme

## X Frame Bollard

**SPEC:** X-Frame Bollard 30"

**FINISH:** Hot Dipped Galvanized (can be Powder Coated)

**HEIGHT ABOVE GRADE:** 36" in

\* **CRASH TEST RATING:** ASTM F3016 S20  
Certified to stop a 5000lb vehicle traveling at 20mph

**SPEC:** X-Frame Bollard 60"

**FINISH:** Hot Dipped Galvanized (can be Powder Coated)

**HEIGHT ABOVE GRADE:** 36 in

\* **CRASH TEST RATING:** ASTM F3016 S20  
Certified to stop a 5000lb vehicle traveling at 20mph

\* The ASTM F3016 was designed to establish a repeatable and reproducible test for assignment of uniform speed and penetration rating designations on protective devices, like a bollard, when impacted by a common vehicle weight. This certified third party testing was performed by Calspan Corp and certification letters can be supplied.

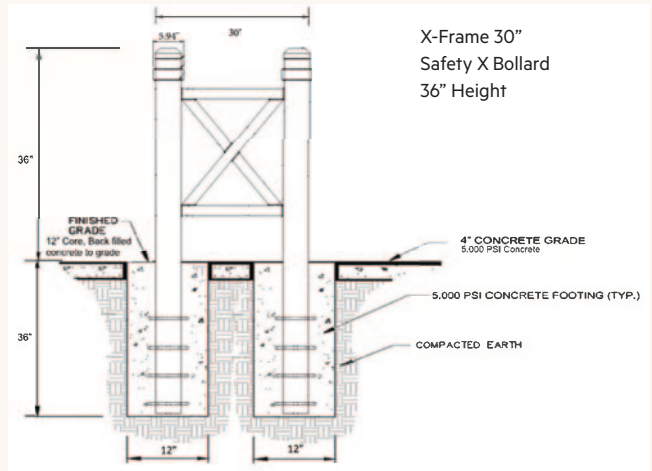

Delivered ready for easy installation without any required underground cage hardware.

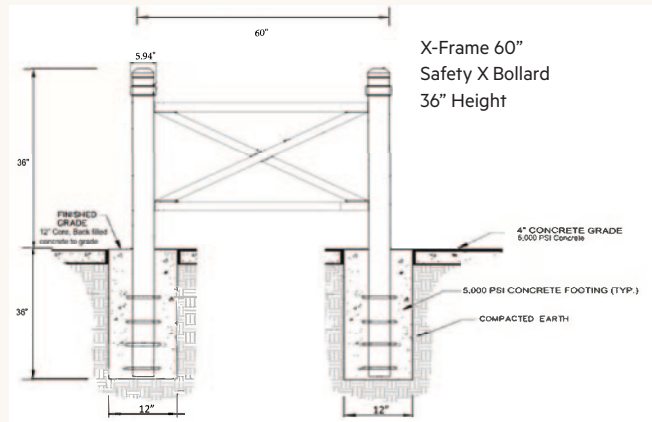

Delivered ready for easy installation without any required underground cage hardware.



PROTECT



POWER



PROTECT



FIXTURE

Boston Group



**Corporate Headquarters** 3 Highwood West, Suite 100, Tewksbury, MA 01876 Tel. 781-395-7417 — 800-225-1633 (toll-free) — sales.us@boston-group.com

**European Headquarters** Sydneystraat 15, Rotterdam, 3047 BP, Netherlands Tel. +31 10 238 14 00 — sales.emea@boston-group.com. [www.boston-group.com](http://www.boston-group.com)

# REFLEX BOLLARD

Super Duty Flex Bollard and Plastic Covers

Super heavy duty flexible bollard used in front of house, back rooms as well as warehouse applications that protect capital assets by deflecting and stopping industrial mobile equipment from the damage they potentially cause.



**Applying ingenuity around the world.**

Boston Group provides total solutions to energize environments, protect assets and support unique shopping or working experience. We listen carefully, look beyond the challenge and come up with smart solutions, exploring new domains every day together with you. From initial concept to full product rollout we expertly guide the process to deliver the right solutions for your needs.



PROTECT



POWER



PROTECT



FIXTURE

Boston Group

**Corporate Headquarters** 3 Highwood West, Suite 100, Tewksbury, MA 01876 Tel. 781-395-7417 — 800-225-1633 (toll-free) — [sales.us@boston-group.com](mailto:sales.us@boston-group.com)

**European Headquarters** Sydneystraat 15, Rotterdam, 3047 BP, Netherlands Tel. +31 10 238 14 00 — [sales.emea@boston-group.com](mailto:sales.emea@boston-group.com) [www.boston-group.com](http://www.boston-group.com)

MADE IN THE USA • V SEPT 2025

# REFLEX BOLLARD

## Super Duty Flex Bollard and Plastic Covers

- The ultimate in Bollard protection.
- Comes with a Polyethylene plastic cover in a variety of colors.
- Inner core made of industrial strength materials for long life.
- Held down by three 5/8 inch concrete bolts.
- There is no exposed mounting hardware to get hung up on.
- Can be removed and refitted to another area easily.
- Will deflect and stop loads up to 22,000 pounds (9975 kg) of impact force.
- Incorporates a foam interior buffer that helps absorb impact to reduce deformation of the outside plastic cover.
- Has unidirectional impact resistant by design.
- Protects, walk-in freezer door hinges, entrance and exits to the back of house, access and egresses throughout the warehouse, pallet racking and columns at the front of the building
- Can be combined with other asset protection rail systems to provide an impenetrable barrier to sensitive areas.
- Heavy duty design that will last for years to come.



PROTECT



7" Reflex Bollard  
BG-REFLEXASSEMBLY7-XXX-60



4.5" Reflex Bollard  
BG-REFLEXASSEMBLY4.5-XXX-52

Standard Cover Heights (Can be field cut to custom sizes)

XXX Denotes that a color tab must be added to the part number at the end of the time of ordering.



POWER



PROTECT



FIXTURE

Boston Group



**Corporate Headquarters** 3 Highwood West, Suite 100, Tewksbury, MA 01876 Tel. 781-395-7417 — 800-225-1633 (toll-free) — sales.us@boston-group.com

**European Headquarters** Sydneystraat 15, Rotterdam, 3047 BP, Netherlands Tel. +31 10 238 14 00 — sales.emea@boston-group.com. [www.boston-group.com](http://www.boston-group.com)

# BOLLARD

Removable, Stainless Steel Bollard

Part of HIPS, the Boston Bollard sharply reduces damage to expensive refrigeration and display cases, doorway entrances, corners, backroom and warehouse areas from the daily assault of pallet jacks, floor scrubbers, foot traffic and more.



## Applying ingenuity around the world.

Boston Group provides total solutions to energize environments, protect assets and support unique shopping or working experience. We listen carefully, look beyond the challenge and come up with smart solutions, exploring new domains every day together with you. From initial concept to full product rollout we expertly guide the process to deliver the right solutions for your needs.



PROTECT



POWER



PROTECT



FIXTURE

Boston Group

**Corporate Headquarters** 3 Highwood West, Suite 100, Tewksbury, MA 01876 Tel. 781-395-7417 — 800-225-1633 (toll-free) — [sales.us@boston-group.com](mailto:sales.us@boston-group.com)

**European Headquarters** Sydneystraat 15, Rotterdam, 3047 BP, Netherlands Tel. +31 10 238 14 00 — [sales.emea@boston-group.com](mailto:sales.emea@boston-group.com) [www.boston-group.com](http://www.boston-group.com)

MADE IN THE USA • V SEPT 2025

# BOLLARD

## Removable, Stainless Steel Bollard

- Each 10-gauge, stainless steel bollard is 100% recyclable and contains a minimum of 60% recycled content.
- The threaded, double-bolt installation eliminates costly 3-foot drilling and the use of toxic adhesives or cement.
- Removable for easy cleaning and/or replacement.
- No exposed hardware.
- Use with HIPS for a complete, high impact floor mounted protection system.

### Stainless Steel Benefits

- Contains a minimum of 60% recycled content.
- A 100% recyclable, sustainable material.
- Contributes towards LEED points; Materials & Resources: credit 4.1 and 4.2, recycled content.
- Easy to clean, durable and corrosion resistant attributes minimize replacement and maintenance costs.

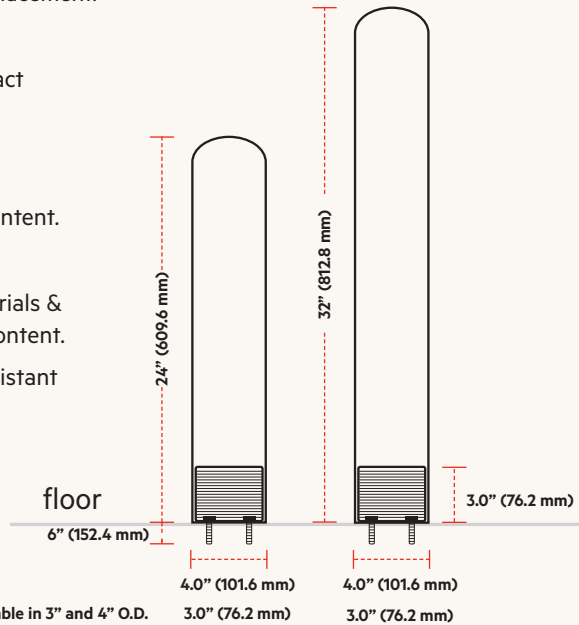

PROTECT

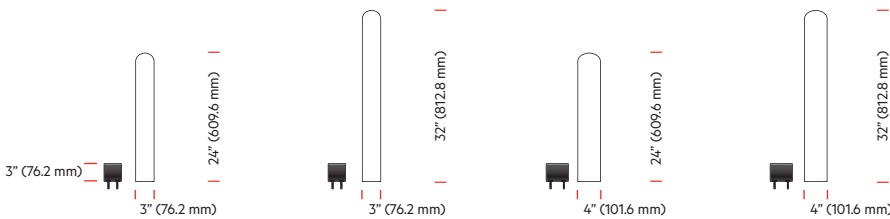

Boston Bollard 24"  
Double Bolt  
3" O.D.  
11 lbs  
HSB3.0-24DB

Boston Bollard 32"  
Double Bolt  
3" O.D.  
16 lbs  
HSB3.0-32DB

Boston Bollard 24"  
Double Bolt  
4" O.D.  
15 lbs  
HSB4.0-24DB

Boston Bollard 32"  
Double Bolt  
4" O.D.  
20 lbs  
HSB4.0-32DB



POWER



PROTECT



FIXTURE



Boston Group

**Corporate Headquarters** 3 Highwood West, Suite 100, Tewksbury, MA 01876 Tel. 781-395-7417 — 800-225-1633 (toll-free) — sales.us@boston-group.com

**European Headquarters** Sydneystraat 15, Rotterdam, 3047 BP, Netherlands Tel. +31 10 238 14 00 — sales.emea@boston-group.com. [www.boston-group.com](http://www.boston-group.com)

# HIPS

## High Impact Protection System

HIPS or High Impact Protection System includes a 10-gauge stainless steel Boston Bollard, rail, and patented 90° Corner Adapter for a continuous rail installation requiring no end caps. The addition of the 90° Corner Adapter triples the impact resistance of standard floor mounted impact protection.



### Applying ingenuity around the world.

Boston Group provides total solutions to energize environments, protect assets and support unique shopping or working experience. We listen carefully, look beyond the challenge and come up with smart solutions, exploring new domains every day together with you. From initial concept to full product rollout we expertly guide the process to deliver the right solutions for your needs.



PROTECT



POWER



PROTECT



FIXTURE

Boston Group

**Corporate Headquarters** 3 Highwood West, Suite 100, Tewksbury, MA 01876 Tel. 781-395-7417 — 800-225-1633 (toll-free) — [sales.us@boston-group.com](mailto:sales.us@boston-group.com)

**European Headquarters** Sydneystraat 15, Rotterdam, 3047 BP, Netherlands Tel. +31 10 238 14 00 — [sales.emea@boston-group.com](mailto:sales.emea@boston-group.com) • [www.boston-group.com](http://www.boston-group.com) •

MADE IN THE USA • V SEPT 2025

# HIPS

## High Impact Protection System



2" Rail Assembly  
(includes 3 stanchions)  
Length 96"  
HSFR96-KIT

2" Rail Assembly  
(includes 3 stanchions)  
Length 120"  
HSFR120-KIT

2" Rail Assembly  
(includes 3 stanchions)  
Length 144"  
HSFR144-KIT



Flush Mount Assembly  
BSF-5



Stanchion  
HSS8



Receptacle & Rubber  
Anchor  
HSR



Collar  
HSC



Rubber End Cap  
for 2" Rail  
REC



2" 90° Corner  
HSFR-90S



2" Diameter Bollard  
Height 32"  
Stainless Steel  
HSB2.0-32DB



3" Diameter Bollard  
Height 24"  
Stainless Steel  
HSB3.0-24DB  
  
Height 32"  
Stainless Steel  
HSB3.0-32DB



4" Diameter Bollard  
Height 24"  
Stainless Steel  
HSB4.0-24DB  
  
Height 32"  
Stainless Steel  
HSB4.0-32DB



For Use with 4" Bollard  
90° Corner Adapter  
HSCA90



For Use with 4" Bollard  
Terminated End  
HSCA



1/2" Concrete Bolt  
602-9601

3/8" Concrete Bolt  
602-9813



POWER



PROTECT



FIXTURE

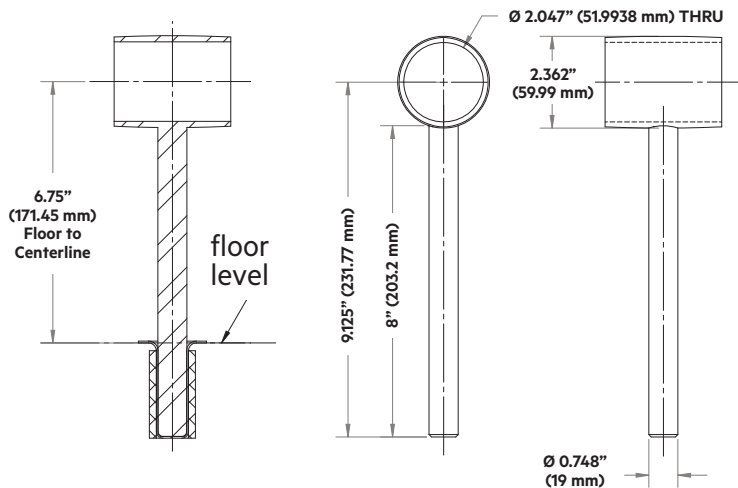
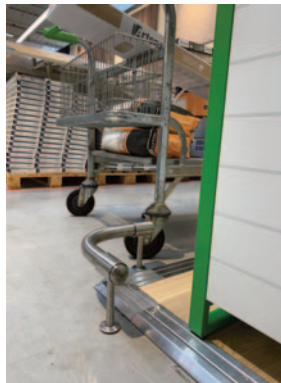

# HIPS

## High Impact Protection System

- Sustainable, stainless steel finish is easy to clean, durable and corrosion resistant.
- The receptacles anchor technology installs easily and eliminates the need for toxic adhesives or cement.
- Solid steel end or continuous rail options.
- Threaded-bolt Bollard application allows for quick installation and/or replacement.
- The complete system is removeable and relocatable.
- Individual component parts are available.
- Comes in standard lengths and assemblies, as well as custom lengths.



PROTECT



POWER



PROTECT



FIXTURE

Boston Group



**Corporate Headquarters** 3 Highwood West, Suite 100, Tewksbury, MA 01876 Tel. 781-395-7417 — 800-225-1633 (toll-free) — sales.us@boston-group.com

**European Headquarters** Sydneystraat 15, Rotterdam, 3047 BP, Netherlands Tel. +31 10 238 14 00 — sales.emea@boston-group.com. [www.boston-group.com](http://www.boston-group.com)

# BARRICADE™

Heavy Duty Floor Mounted Bumper

The simple unique design allows for less component parts, easier assembly and installation with maximum protection. We understand the need to protect fixtures and the appearance of your store from damage caused by equipment, carts and customers. That's why the Barricade™ stands tall to protect your investments.



## Applying ingenuity around the world.

Boston Group provides total solutions to energize environments, protect assets and support unique shopping or working experience. We listen carefully, look beyond the challenge and come up with smart solutions, exploring new domains every day together with you. From initial concept to full product rollout we expertly guide the process to deliver the right solutions for your needs.



PROTECT



POWER



PROTECT



FIXTURE

Boston Group

**Corporate Headquarters** 3 Highwood West, Suite 100, Tewksbury, MA 01876 Tel. 781-395-7417 — 800-225-1633 (toll-free) — [sales.us@boston-group.com](mailto:sales.us@boston-group.com)

**European Headquarters** Sydneystraat 15, Rotterdam, 3047 BP, Netherlands Tel. +31 10 238 14 00 — [sales.emea@boston-group.com](mailto:sales.emea@boston-group.com). [www.boston-group.com](http://www.boston-group.com)

MADE IN THE USA • V SEPT 2025

# BARRICADE™

## Heavy Duty Floor Mounted Bumper

- Optimized structural rail design for maximum impact strength.
- Enlarged 3.9" impact zone of the rail continues to protect where others fall short.
- Center impact heights: 5.6".
- Less component parts, easier assembly and installation.
- Comes in standard lengths of 4', 6', 8', 10' and 12' as well as custom lengths.
- Stainless Steel stanchions and receptacles that will not rust.
- Removes easily for cleaning.
- Available in any color specification to match your store décor.

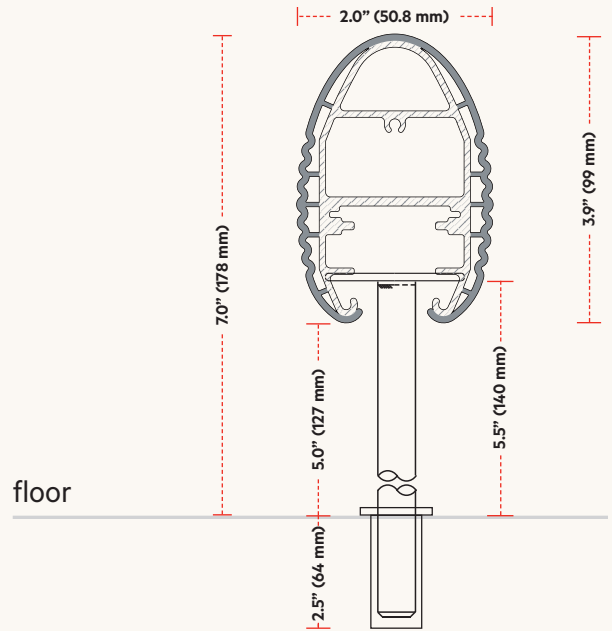
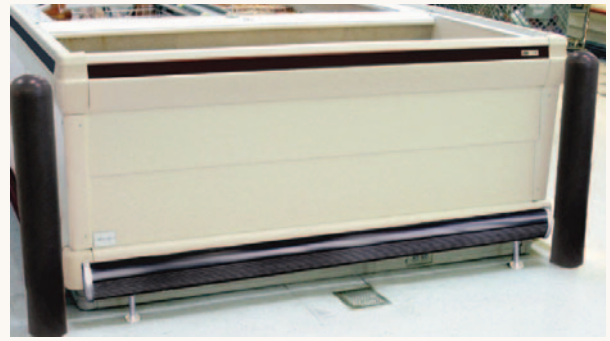

PROTECT

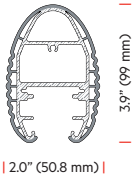

Aluminum Rail  
Rigid Vinyl Cover  
BBRA-144-XXX  
144 denotes length in inches

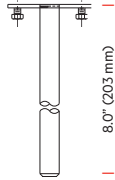

Carrier Support  
Stainless Steel  
BCS-8



Floor Receptacle  
Stainless Steel and  
Rubber Anchor  
HSR

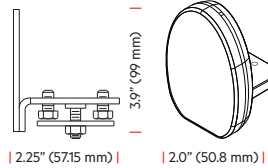

Flat End Cap  
Cast Aluminum  
BBEC

XXX Denotes that a color tab must be added to the part number at the end of the time of ordering. Custom heights, lengths and colors require minimum lead time and quantities. See separate color chart for color options.  
X Denotes virgin material.



POWER



PROTECT



FIXTURE

Boston Group



# THE BOSS®

Floor Mounted Bumper System

Look around and you'll see some of the most vulnerable areas of your store: the refrigeration and display cases, shopping cart vestibules, store fronts and sliding doors. The Boss® is a floor-mounted bumper system that protects retailers from costly damage caused by motorized floor scrubbers, pallet jacks and shopping carts.



## Applying ingenuity around the world.

Boston Group provides total solutions to energize environments, protect assets and support unique shopping or working experience. We listen carefully, look beyond the challenge and come up with smart solutions, exploring new domains every day together with you. From initial concept to full product rollout we expertly guide the process to deliver the right solutions for your needs.



PROTECT



POWER



PROTECT



FIXTURE

Boston Group

**Corporate Headquarters** 3 Highwood West, Suite 100, Tewksbury, MA 01876 Tel. 781-395-7417 — 800-225-1633 (toll-free) — [sales.us@boston-group.com](mailto:sales.us@boston-group.com)

**European Headquarters** Sydneystraat 15, Rotterdam, 3047 BP, Netherlands Tel. +31 10 238 14 00 — [sales.emea@boston-group.com](mailto:sales.emea@boston-group.com) • [www.boston-group.com](http://www.boston-group.com) •

MADE IN THE USA • V SEPT 2025

# THE BOSS<sup>®</sup>

## Floor Mounted Bumper System

- Material options are virgin flex or rigid vinyl (PVC).
- Manufactured with a 2" aluminum rail and a full rounded cover.
- Comes with crash-resistant flat metal end caps.
- The stainless steel carrier support allows for easy cleaning, removal or replacement.
- Stands 6.375" tall when installed to the floor receptacle.
- Comes in standard lengths of 4', 6', 8', 10' and 12'.
- Stock black and gray.
- Ships in 5-7 days depending on order size.

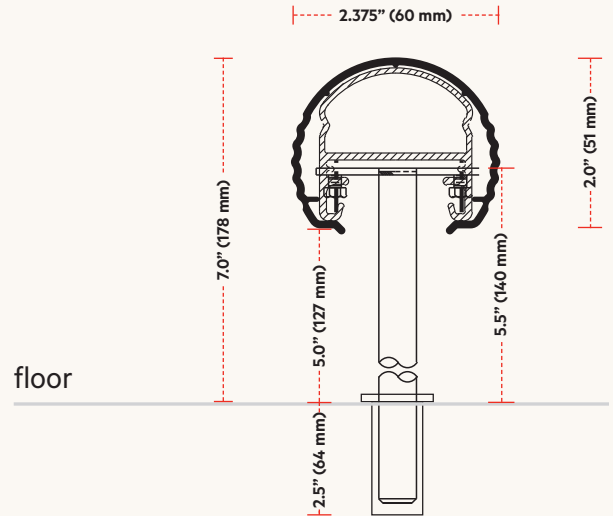

PROTECT



Aluminum Rail  
Flexible Cover  
Virgin Vinyl (PVC)  
BOSS-XX-XXX

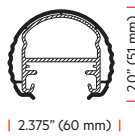

Aluminum Rail  
Rigid Cover  
Virgin Vinyl (PVC)  
BOSS-RI-XX-XXX

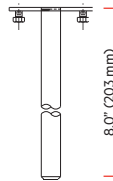

Carrier Support  
Stainless Steel  
BCS-8

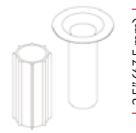

Floor Receptacle  
Stainless Steel and  
Rubber Anchor  
HSR

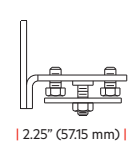

Flat End Cap  
Anodized Steel  
BFE-1000

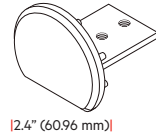

XX Denotes length in inches XXX Denotes that a color tab must be added to the part number at the end of the time of ordering.  
Custom lengths and colors require minimum lead time and quantities. See separate color chart for color options.



POWER



PROTECT



FIXTURE

Boston Group



# Box Rail

## Multi-purpose Fence Rail Guard

**Box Rail 48, Box Rail 20 and Box Rail 7 provides extreme protection for your back room and vestibule. Our complete range of Box Rail products are made of all steel components that protect against the daily punishment from fork trucks, hand trucks, equipment movers.**

- Durable Protection with Easy Access
- Bolt Down 1/2" Thick Steel Base
- Tapered Ends
- Galvanized Rails that do not rust
- Flush on Aisle Side
- Heavy Duty Gauge Steel
- Rail Height 7"
- Installed with Concrete Bolts
- Removable Rails



### Applying ingenuity around the world.

Boston Group provides total solutions to energize environments, protect assets and support unique shopping or working experience. We listen carefully, look beyond the challenge and come up with smart solutions, exploring new domains every day together with you. From initial concept to full product rollout we expertly guide the process to deliver the right solutions for your needs.



PROTECT



POWER



PROTECT



FIXTURE

Boston Group

**Corporate Headquarters** 3 Highwood West, Suite 100, Tewksbury, MA 01876 Tel. 781-395-7417 — 800-225-1633 (toll-free) — [sales.us@boston-group.com](mailto:sales.us@boston-group.com)

**European Headquarters** Sydneystraat 15, Rotterdam, 3047 BP, Netherlands Tel. +31 10 238 14 00 — [sales.emea@boston-group.com](mailto:sales.emea@boston-group.com) [www.boston-group.com](http://www.boston-group.com)

MADE IN THE USA • V SEPT 2025

# Box Rail

## Multi-purpose Fence Rail Guard

- Durable Protection with Easy Access
- Bolt Down 1/2" Thick Steel Base
- Tapered Ends
- Galvanized Rails that do not rust
- Flush on Aisle Side
- Heavy Duty Gauge Steel
- Rail Height 7"
- Installed with Concrete Bolts
- Removable Rails



Box Rail 7  
Galvanized Rail  
BG-BOX7-8RL



Box Rail 7  
90o Corner Galvanized  
BG-BOX7-90CNR



Box Rail 7  
Standard Bracket  
Galvanized  
BG-BOX7-BRKT



Box Rail 7  
Middle Bracket  
Galvanized  
BG-BOX7-BRKT-M



Box Rail 7  
Gondola End  
BG-BOX7-GND-4



Box Rail 7  
Starter Kit  
BG-BOX7-SK-4



Box Rail 20  
Vertical Rail 5'  
BG-20-5RAIL



Box Rail 20  
Left Hand Post  
BG-20-LHP-923



Box Rail 20  
Two Way Pass  
Through  
BG-20-WY-923



Box Rail 20  
Right Hand Post  
BG-20-RHP-923



Box Rail 48  
Vertical Rail 5'  
BG-20-5RAIL



Box Rail 48  
Left Hand Post  
BG-48-LHP-923



Box Rail 20  
Two Way Pass  
Through  
BG-20-WY-923



Box Rail 48  
Right Hand Post  
BG-48-RHP-923



Box Rail 48  
90° Corner  
BG-48-90-923



POWER



PROTECT



FIXTURE

Boston Group



**Corporate Headquarters** 3 Highwood West, Suite 100, Tewksbury, MA 01876 Tel. 781-395-7417 — 800-225-1633 (toll-free) — sales.us@boston-group.com

**European Headquarters** Sydneystraat 15, Rotterdam, 3047 BP, Netherlands Tel. +31 10 238 14 00 — sales.emea@boston-group.com. [www.boston-group.com](http://www.boston-group.com)

# WALLGUARDS

Wall Mounted Corner Guards

Wall corners take a beating every day from shopping carts, foot traffic and cleaning equipment. That's why ecoGuards are made tough enough to stand up to high-traffic areas. They're easy to clean and maintain. Choose from durable rigid plastic material or stainless steel.



## Applying ingenuity around the world.

Boston Group provides total solutions to energize environments, protect assets and support unique shopping or working experience. We listen carefully, look beyond the challenge and come up with smart solutions, exploring new domains every day together with you. From initial concept to full product rollout we expertly guide the process to deliver the right solutions for your needs.



PROTECT



POWER



PROTECT



FIXTURE



Boston Group

**Corporate Headquarters** 3 Highwood West, Suite 100, Tewksbury, MA 01876 Tel. 781-395-7417 — 800-225-1633 (toll-free) — [sales.us@boston-group.com](mailto:sales.us@boston-group.com)

**European Headquarters** Sydneystraat 15, Rotterdam, 3047 BP, Netherlands Tel. +31 10 238 14 00 — [sales.emea@boston-group.com](mailto:sales.emea@boston-group.com) • [www.boston-group.com](http://www.boston-group.com) •

MADE IN THE USA • V SEPT 2025

# WALLGUARDS

## Wall Mounted Corner Guards

- Many different sizes are available in both stainless steel and plastic. Plastic option offers multiple color choices and finishes .
- Applies easily to existing walls or cases with adhesive; updating is easy and inexpensive, too.
- Stainless steel is easy to clean, durable and corrosion resistant.
- Protects costly fixtures from added wear and tear while enhancing the appearance of your environment.



PROTECT

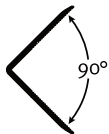

Stainless Steel  
90° Corner  
1.5" x 1.5"  
SMCG1.5-XX

Stainless Steel  
90° Corner  
2" x 2"  
SMCG2.0-XX

Stainless Steel  
90° Corner  
3" x 3"  
SMCG3.0-XX

Stainless Steel  
90° Corner  
4" x 4"  
SMCG4.0-XX

Stainless Steel  
90° Corner  
5" x 5"  
SMCG5.0-XX

Stainless Steel  
90° Corner  
6" x 6"  
SMCG6.0-XX

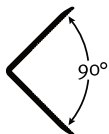

Rigid PVC  
90° Corner  
1" x 1"  
RVCG-1-XXX

Rigid PVC  
90° Corner  
1.5" x 1.5"  
RVCG-15-XXX

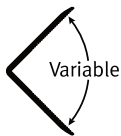

Rigid Flexible  
with flexible hinge  
Corner Guard  
1" x 1"  
FHCG-1-XXX

Rigid Flexible  
with flexible hinge  
Corner Guard  
1.5" x 1.5"  
FHCG-15-XXX



POWER



PROTECT



FIXTURE

\*Made to Order

XX Denotes length in inches from 12" to 72".

XXX Denotes that a color tab must be added to the part number at the time of ordering. See separate color chart for color options.



Boston Group

**Corporate Headquarters** 3 Highwood West, Suite 100, Tewksbury, MA 01876 Tel. 781-395-7417 — 800-225-1633 (toll-free) — sales.us@boston-group.com

**European Headquarters** Sydneystraat 15, Rotterdam, 3047 BP, Netherlands Tel. +31 10 238 14 00 — sales.emea@boston-group.com. [www.boston-group.com](http://www.boston-group.com)

# GUIDANCE & SECURITY RAILING SYSTEM

Stainless Steel

Guidance and security railings are essential elements in ensuring safety and accessibility in retail and other environments. They help guide customers, prevent accidents, and create a secure atmosphere. They serve to clearly mark entrances, exits, and paths, and cart areas to help customers navigate the store or any environment efficiently and safely



**Applying ingenuity around the world.**

Boston Group provides total solutions to energize environments, protect assets and support unique shopping or working experience.

We listen carefully, look beyond the challenge and come up with smart solutions, exploring new domains every day together with you.

From initial concept to full product rollout we expertly guide the process to deliver the right solutions for your needs.



PROTECT



POWER



PROTECT



FIXTURE

Boston Group

**Corporate Headquarters** 3 Highwood West, Suite 100, Tewksbury, MA 01876 Tel. 781-395-7417 — 800-225-1633 (toll-free) — [sales.us@boston-group.com](mailto:sales.us@boston-group.com)

**European Headquarters** Sydneystraat 15, Rotterdam, 3047 BP, Netherlands Tel. +31 10 238 14 00 — [sales.emea@boston-group.com](mailto:sales.emea@boston-group.com) [www.boston-group.com](http://www.boston-group.com)

MADE IN THE USA • V SEPT 2025

# GUIDANCE & SECURITY RAILING SYSTEM

## Stainless Steel

- Post tubes are 2.375" O.D. (outside diameter) X 35.0" Height
- Railing are 1.625" O.D.
- Tubing meets appropriate ASTM standard finishes
- Rails can be custom cut and configured
- 304 Stainless mounts with standard screw and anchor hardware
- Posts feature a steel base plate welded to heavy duty steel tube with a finished post cap
- Rail outlets bolt directly to the post and a 0.25" set screw securely lock the rail into position.



## PROTECT

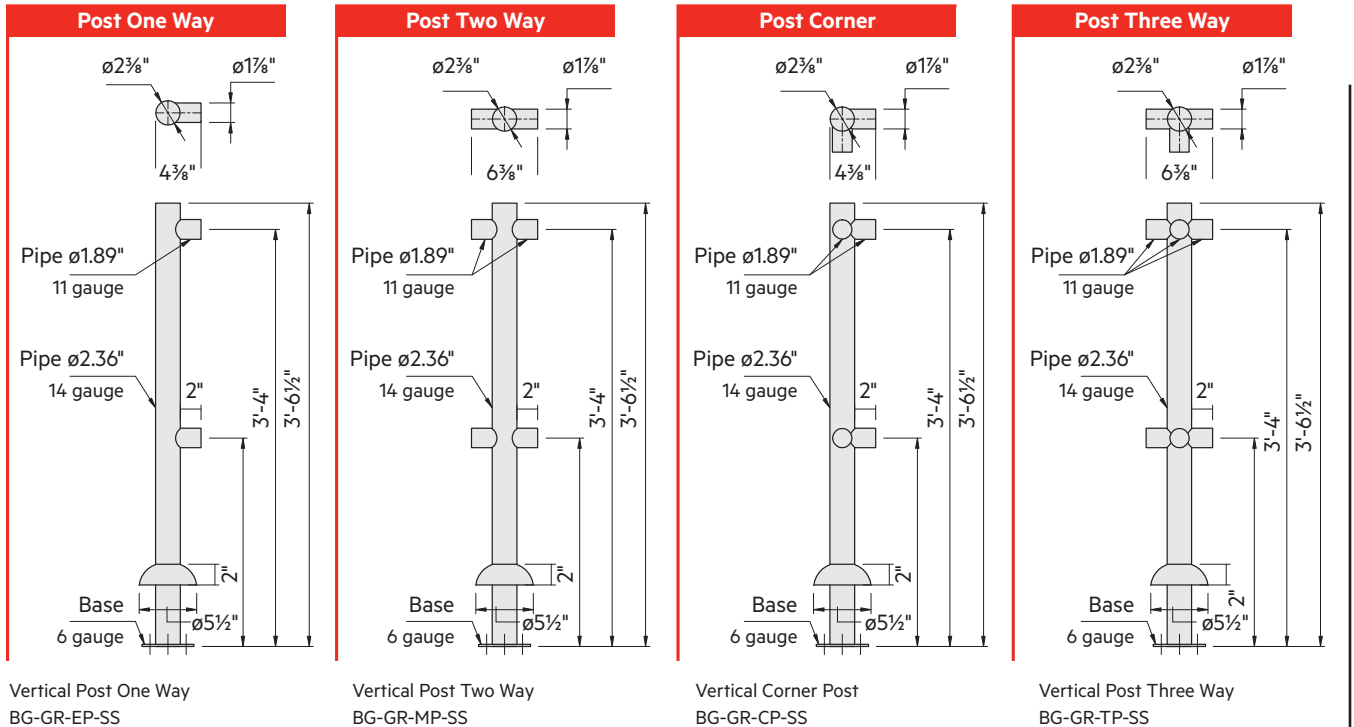

### Rails

Rails available in 3 lengths: 47", 59", and 68" long  
BG-GR-47-RAIL | BG-GR-59-RAIL | BG-GR-68-RAIL

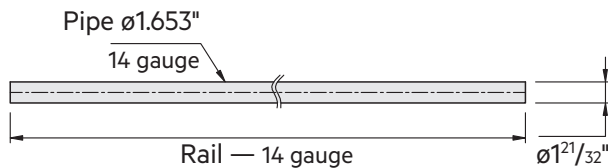

Boston Group

# ECOGUARDS

Stainless Steel Floor Mounted Corner Guards  
and Warehouse Racking Protectors

Boston manufactures a complete line of 10-gauge, brush-finished stainless steel and CRS corner guards that can withstand impact up to 4,000 lbs! For your highest-traffic areas, they'll protect your corners from the daily assault of shopping carts, electric floor scrubbers, even pallet jacks.



## Applying ingenuity around the world.

Boston Group provides total solutions to energize environments, protect assets and support unique shopping or working experience. We listen carefully, look beyond the challenge and come up with smart solutions, exploring new domains every day together with you. From initial concept to full product rollout we expertly guide the process to deliver the right solutions for your needs.



PROTECT

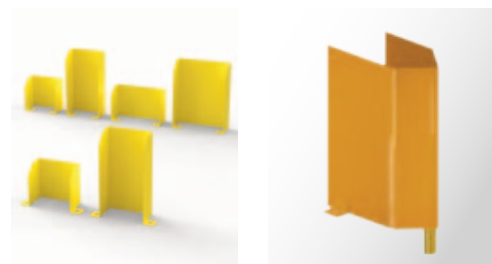
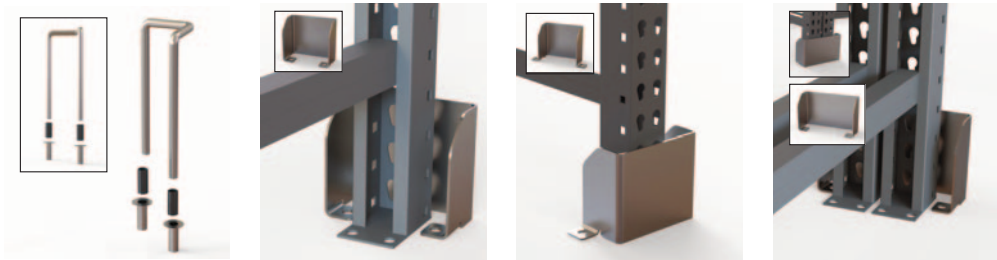
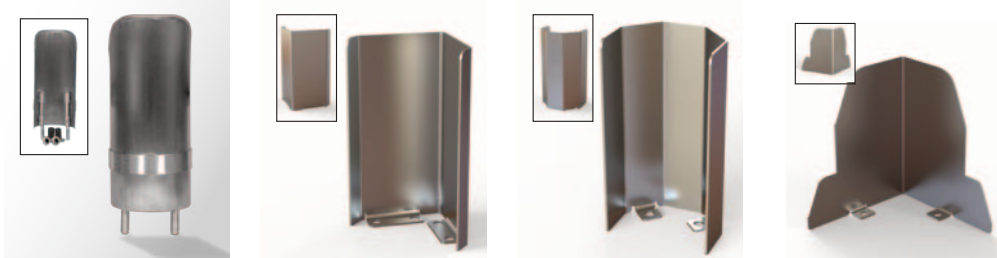

POWER



PROTECT



FIXTURE

Boston Group

# ECOGUARDS

## Stainless Steel Floor Mounted Corner Guards and Warehouse Racking Protectors



### SSCPU-XX

- #10 GA Stainless Steel
- Structural flanges
- One piece design
- Corrosion resistant

Part #	Height
SSCPU-12	12"
SSCPU-18	18"

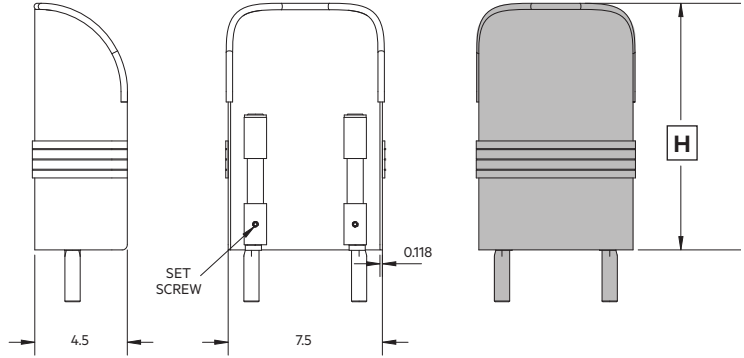

\*Comes with Floor Inserts: HSR-KIT



### SSCP-1P-XX

- #10 GA Stainless Steel
- Structural flanges
- One piece design
- Corrosion resistant

Part #	Height
SSCP-1P-12	12"
SSCP-1P-18	18"
SSCP-1P-24	24"

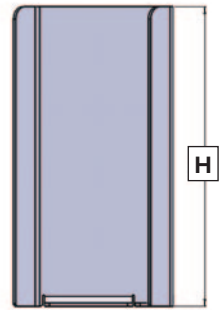
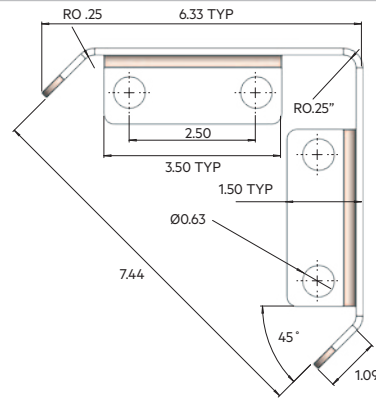

\*All corner protectors ship with (4) anchor bolts #602-10-301



### SSCP-1P-5SEG-XX

- #10 GA Stainless Steel
- Structural flanges
- One piece design
- Corrosion resistant

Part #	Height
SSCP-1P-5SEG-12	12"
SSCP-1P-5SEG-18	18"
SSCP-1P-5SEG-24	24"

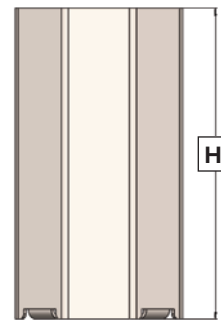
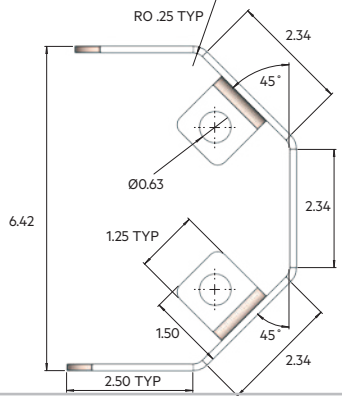

\*All corner protectors ship with (2) anchor bolts #602-10-301

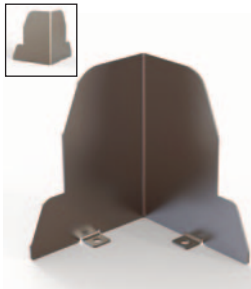

### SSCP-1P-ANG-XX

- #10 GA Stainless Steel
- Structural flanges
- One piece design
- Corrosion resistant

Part #	Height
SSCP-1P-ANG-12	12"
SSCP-1P-ANG-18	18"

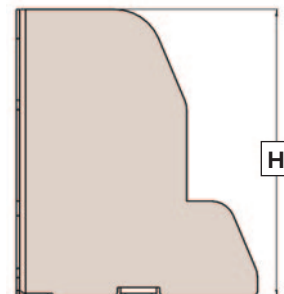
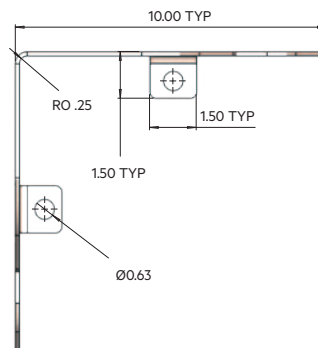

**Boston Group**

\*All racking protectors ship with (2) anchor bolts #602-10-301

**Corporate Headquarters** 3 Highwood West, Suite 100, Tewksbury, MA 01876 Tel. 781-395-7417 — 800-225-1633 (toll-free) — sales.us@boston-group.com

**European Headquarters** Sydneystraat 15, Rotterdam, 3047 BP, Netherlands Tel. +31 10 238 14 00 — sales.emea@boston-group.com. [www.boston-group.com](http://www.boston-group.com)

# ECOGUARDS

## Stainless Steel Floor Mounted Corner Guards and Warehouse Racking Protectors



### Uniguard SS Corner Guard

- #3/4"OD Stainless Steel ROD
- SS Floor Insert with Rubber insert
- One piece design
- Corrosion resistant



Part #	Height
BG-UNIGUARD-12	9 5/8" AFF
BG-UNIGUARD-24	24" AFF

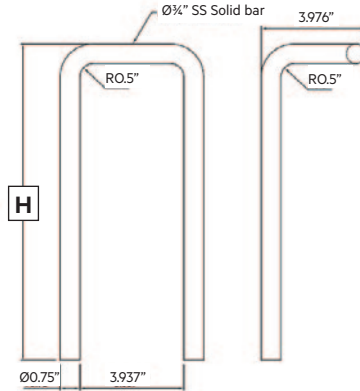

SS Insert 3/4": 2 PCS



Rubber Insert: 2 PCS

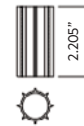

\*All Uniguard stainless steel corner guards ship with (2) HSR-KIT Receptacle & Anchor\*\*Stainless Steel/Rubber

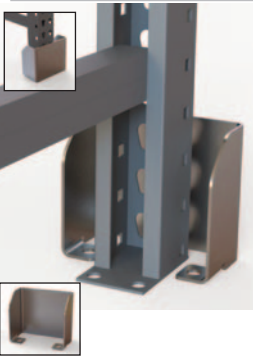

### WRG-1W-6

- #10 GA Stainless Steel
- Structural flanges
- One piece design
- Corrosion resistant

Part #	Height
WRG-1W-6	6"
WRG-1W-12	12"

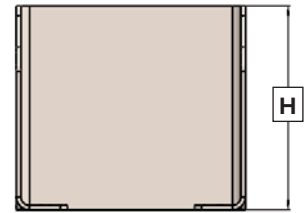
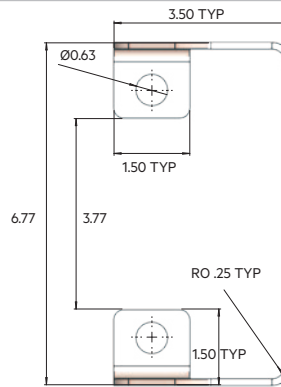

\*All racking protectors ship with (2) anchor bolts #602-10-301

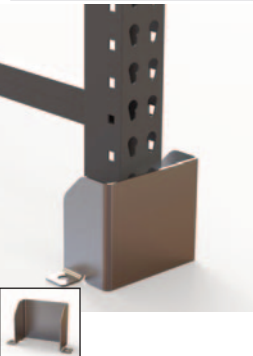

### WRG-1W-OF-XX

- #10 GA Stainless Steel
- Structural flanges
- One piece design
- Corrosion resistant

Part #	Height
WRG-1W-OF-6	6"
WRG-1W-OF-12	12"

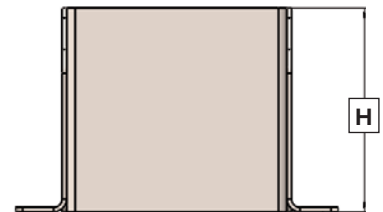
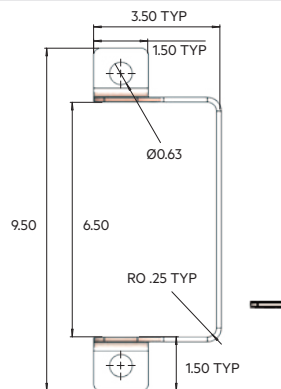

\*All racking protectors ship with (2) anchor bolts #602-10-301

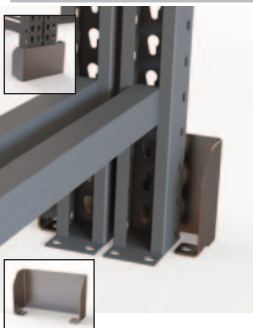

### WRG-2W-XX

- #10 GA Stainless Steel
- Structural flanges
- One piece design
- Corrosion resistant

Part #	Height
WRG-2W-6	6"
WRG-2W-12	12"

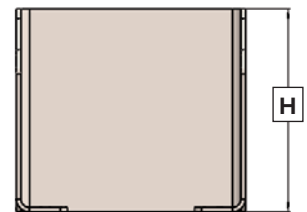
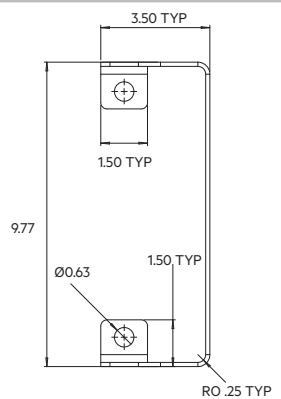

# ECOGUARDS

## Stainless Steel Floor Mounted Corner Guards and Warehouse Racking Protectors

- Manufactured of 10-gauge, heavy-duty stainless steel and CRS for durable, rust-free service.
- Half-round profile with posts and the universal mount guards remove quickly for cleaning.
- Universal mount corner guards fit most existing hole position, making it ideal for replacement applications.
- All styles withstand impact up to 4,000 pounds (rating based on impact at 3" above floor level).
- Installs easily with basic tools.
- All profiles are available in standard and custom heights.
- Materials and finishes include stainless steel, galvanized, powder coated CRS.

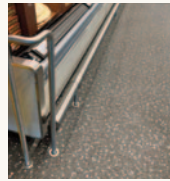

### Stainless Steel Benefits

- Contains a minimum of 60% recycled content.
- A 100% recyclable, sustainable material.
- Contributes towards LEED points; Materials & Resources: credit 4.1 and 4.2, recycled content.
- Easy to clean, durable and corrosion resistant attributes minimize replacement and maintenance costs.



## PROTECT



### WRG-1W-6

- #13 GA Powder Coated Steel – Safety Yellow
- Structural flanges
- One piece design
- Corrosion resistant

Part #	H Height	W Width	F Flange Position
WRG-1W-CRS-6-923	6"	6.30"	Inside Body
WRG-1W-CRS-12-923	12"	6.30"	Inside Body
WRG-1W-CRS-OF-6-923	6"	6.30"	Outside Body
WRG-1W-CRS-OF-12-923	12"	6.30"	Outside Body
WRG-2W-CRS-6-923	6"	9.30"	Inside Body
WRG-2W-CRS-12-923	12"	9.30"	Inside Body

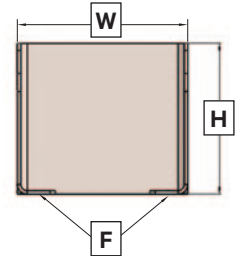

\*All racking protectors ship with (2) anchor bolts #602-10-301



### Pallet Rack Protector

- #10 GA Stainless Steel
- Structural flanges
- One piece design
- Corrosion resistant

Part #	Height
PRP-12	12"

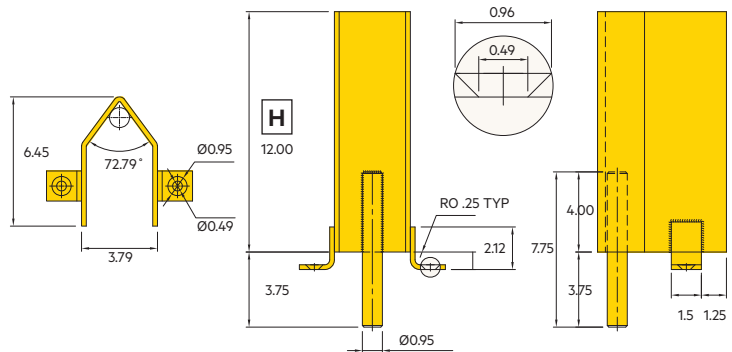

\*Comes with Flush Bolts: #602-9655

Boston Group



**Corporate Headquarters** 3 Highwood West, Suite 100, Tewksbury, MA 01876 Tel. 781-395-7417 — 800-225-1633 (toll-free) — sales.us@boston-group.com

**European Headquarters** Sydneystraat 15, Rotterdam, 3047 BP, Netherlands Tel. +31 10 238 14 00 — sales.emea@boston-group.com [www.boston-group.com](http://www.boston-group.com)

MADE IN THE USA • V SEPT 2025

# ECOBASE

ecoRigid® Cove Base & Flexible Flat Base

Whether you're remodelling or building a new store, office, airport or hospital, the Boston ecoBase offers a variety of cost-effective base molding options that will protect and enhance your walls. It offers ideal impact protection from the damage caused by carts, foot traffic and cleaning equipment.



## Applying ingenuity around the world.

Boston Group provides total solutions to energize environments, protect assets and support unique shopping or working experience. We listen carefully, look beyond the challenge and come up with smart solutions, exploring new domains every day together with you. From initial concept to full product rollout we expertly guide the process to deliver the right solutions for your needs.



PROTECT

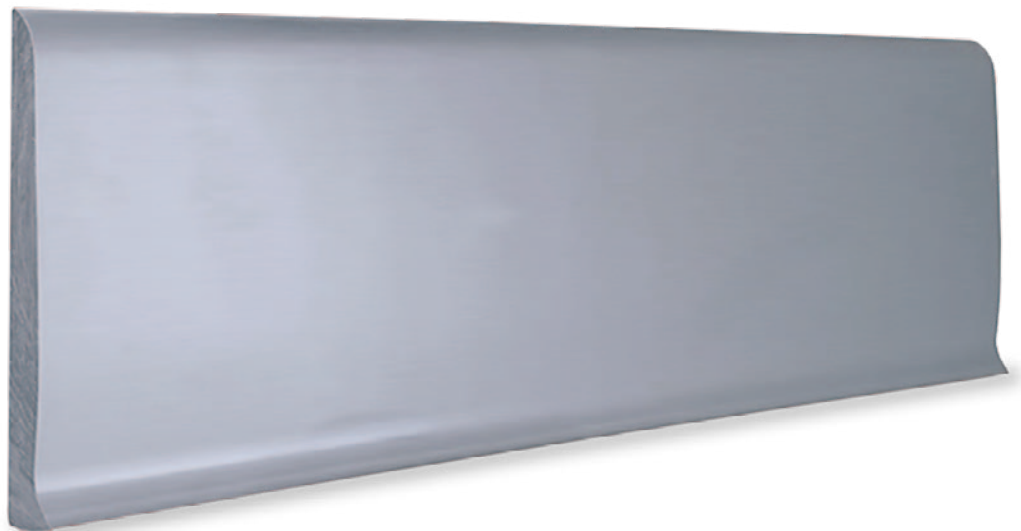

POWER



PROTECT



FIXTURE

Boston Group

**Corporate Headquarters** 3 Highwood West, Suite 100, Tewksbury, MA 01876 Tel. 781-395-7417 — 800-225-1633 (toll-free) — [sales.us@boston-group.com](mailto:sales.us@boston-group.com)

**European Headquarters** Sydneystraat 15, Rotterdam, 3047 BP, Netherlands Tel. +31 10 238 14 00 — [sales.emea@boston-group.com](mailto:sales.emea@boston-group.com) • [www.boston-group.com](http://www.boston-group.com) •

MADE IN THE USA • V SEPT 2025

# ECOBASE

## ecoRigid® Cove Base & Flexible Flat Base

- Material options include heavy-duty ecoRigid® PolyBostylene®, and virgin flexible or rigid vinyl.
- 40-50% thicker than the competition.
- Applies easily to existing walls or cases with adhesive, silicone or double-sided tape; updating is easy and inexpensive too.
- Flexible flat base ships in 100' rolls saving storage space requirements.
- Stock black ships in 24 hours.



### ecoRigid Benefits

- Using 100% pvc-free ecoRigid® cove base protects the environment and your investment against unnecessary damage.
- A 100% recyclable, sustainable material.
- RoHS Compliant.
- Free of Chlorine and Bromine hazardous chemicals.
- UL-94HB Fire Rating.



PROTECT



ecoRigid®  
PolyBostylene® Solid  
Cove Base 4"  
length 12' piece  
PBSBCB4-XXX

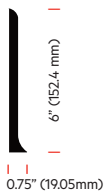

ecoRigid®  
PolyBostylene® Solid  
Cove Base 6"  
length 12' piece  
PBSBCB6-XXX

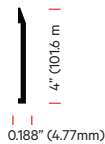

Flexible Flat Base 4"  
(without tape)  
length 100' coil  
FLFB4NT-XXX

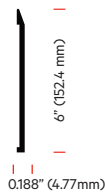

Flexible Flat Base 6"  
(without tape)  
length 100' coil  
FLFB6NT-XXX



Flexible Flat Base 4"  
(with double-sided  
tape) length 100' coil  
FLFB4-XXX

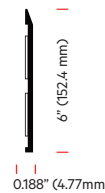

Flexible Flat Base 6"  
(with double-sided  
tape) length 100' coil  
FLFB6-XXX

XXX Denotes that a color tab must be added to the part number at the end of the time of ordering. Custom and standard colors require minimum lead time and quantities. See separate color chart for color options.



POWER



PROTECT



FIXTURE



Boston Group

**Corporate Headquarters** 3 Highwood West, Suite 100, Tewksbury, MA 01876 Tel. 781-395-7417 — 800-225-1633 (toll-free) — sales.us@boston-group.com

**European Headquarters** Sydneystraat 15, Rotterdam, 3047 BP, Netherlands Tel. +31 10 238 14 00 — sales.emea@boston-group.com. [www.boston-group.com](http://www.boston-group.com)

# ECOFLEX<sup>®</sup>

Minimum 80% recycled material

All ecoSeries<sup>®</sup> products retain the same high quality and high performance characteristics to protect walls and fixtures as the original Boston Bumper<sup>®</sup>. From beginning to end, so you are assured superior quality that has made Boston the trusted name in impact protection.



## Applying ingenuity around the world.

Boston Group provides total solutions to energize environments, protect assets and support unique shopping or working experience. We listen carefully, look beyond the challenge and come up with smart solutions, exploring new domains every day together with you. From initial concept to full product rollout we expertly guide the process to deliver the right solutions for your needs.



PROTECT



POWER



PROTECT



FIXTURE

Boston Group

**Corporate Headquarters** 3 Highwood West, Suite 100, Tewksbury, MA 01876 Tel. 781-395-7417 — 800-225-1633 (toll-free) — [sales.us@boston-group.com](mailto:sales.us@boston-group.com)

**European Headquarters** Sydneystraat 15, Rotterdam, 3047 BP, Netherlands Tel. +31 10 238 14 00 — [sales.emea@boston-group.com](mailto:sales.emea@boston-group.com). [www.boston-group.com](http://www.boston-group.com)

MADE IN THE USA • V SEPT 2025

# ECOFLEX®

Minimum 80% recycled material

**Top**

**Base**

**Base**



**EcoFlex® 1000**



1" ecoFlex Vinyl Top  
72' coils  
TFC1000-XXX\*

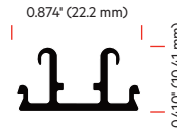

1" ecoBase Rigid Vinyl  
12' sections  
BR1000R



1" Aluminum Base  
1 sections  
BA1000



**EcoFlex® 2000**



2" ecoFlex Vinyl Top  
36' coils  
TFC2000-XXX\*

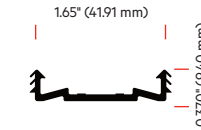

2" ecoFlex Rigid Vinyl  
12' sections  
BR2000R

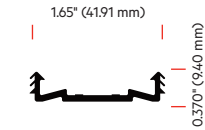

2" Aluminum Base  
12 sections  
BA2000

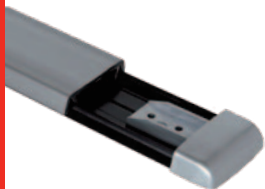

**EcoFlex® 2100**

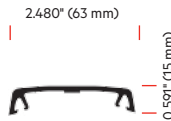

2.5" ecoFlex Vinyl Top  
72' coils  
TFC2100-XXX

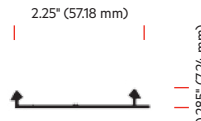

2.5" Recycled Vinyl Base  
12' sections  
BR2100R



**EcoFlex® 3300**

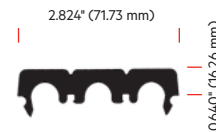

3" ecoFlex Vinyl Top  
36' coils  
TFC3300-XXX\*

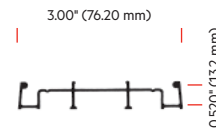

3" ecoFlex Rigid Vinyl  
12' sections  
BR3300-XXX  
BR3300R (black only)

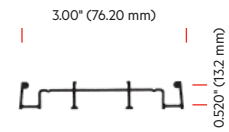

3" Aluminum Base  
12' sections  
BA3300



POWER



PROTECT



FIXTURE

XXX Denotes that a color tab must be added to the part number at the end of the time of ordering. Custom and standard colors require minimum lead time and quantities. See separate color chart for color options.

\*Some colors available in virgin material only. Check with our customer service.

**End Cap**

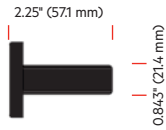

1" Flat  
Polyostylene® End Cap  
144 pieces per box  
PBEF1000-XXX  
EF1000-XXX

**End Cap**

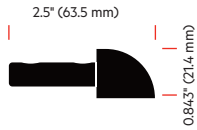

1" Round  
Vinyl End Cap  
288 pieces per box  
ER1000-XXX

**Corner Cap**

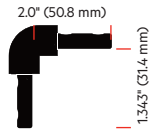

1" 90°  
Vinyl Corner Cap  
144 pieces per box  
CN1000-XXX

**Corner Cap**

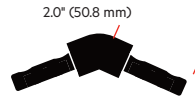

1 135°  
Vinyl Corner Cap  
144 pieces per box  
CX1000-XXX  
PBCX1000-XXX

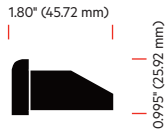

2" Flat  
Vinyl End Cap  
144 pieces per box  
PBEF2000-XXX  
ER2000-XXX

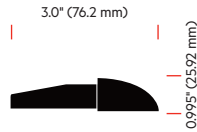

2" Round  
Vinyl End Cap  
144 pieces per box  
EF2000-XXX

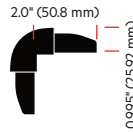

2" 90°  
Vinyl Corner Cap  
144 pieces per box  
CN2000-XXX

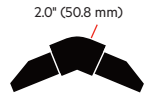

2" 135°  
Vinyl Corner Cap  
144 pieces per box  
CX2000-XXX  
PBCX2000-XXX

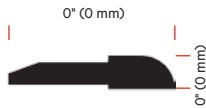

2.5" Round  
Vinyl End Cap  
72 pieces per box  
ER2100-XXX

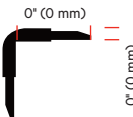

2.5" Vinyl 90°  
Corner Cap  
72 pieces per box  
CN2100-XXX

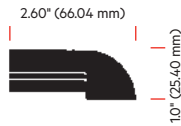

3" Round  
Vinyl End Cap  
72 pieces per box  
ER3300-XXX

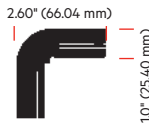

3" 90°  
Vinyl Corner Cap  
72 pieces per box  
CN3300-XXX



# ECOFLEX<sup>®</sup>

Minimum 80% recycled material

- Profile & base combined contain a minimum of 80% recycled content.
- Recycled content claim validated by UL Environment.
- A virgin cosmetic skin for optimum aesthetics and color flexibility.
- Engineered to easily radius curved or round surfaces.
- 100% recyclable, sustainable material.
- Does not cost a premium. Costs 1/3 less than traditional Boston Bumper<sup>®</sup>.
- Compatible with all ecoRigid<sup>®</sup> and traditional Boston Bumper<sup>®</sup> parts.
- Contributes towards LEED points; Materials & Resources: credit 4.1 and 4.2, recycled content.
- Continuous rolls of bumper cover eliminate scrap and reduce storage space requirements.
- UL-94 V-0 Fire Rating.
- Simple installation with a pre-slotted base channel.
- Highest impact resistance.
- Vast color options.



PROTECT



POWER



PROTECT



FIXTURE

Boston Group



# ECOSUPERFLEX<sup>®</sup>

1" radius, 80% recycled, flexible ecoSeries<sup>®</sup>

All ecoSeries<sup>®</sup> products retain the same high quality and high performance characteristics to protect walls and fixtures as the original Boston Bumper<sup>®</sup>. The recycling and green manufacturing process is performed by Boston from beginning to end, so you are assured superior quality.



## Applying ingenuity around the world.

Boston Group provides total solutions to energize environments, protect assets and support unique shopping or working experience. We listen carefully, look beyond the challenge and come up with smart solutions, exploring new domains every day together with you. From initial concept to full product rollout we expertly guide the process to deliver the right solutions for your needs.



PROTECT



POWER



PROTECT



FIXTURE



Boston Group

**Corporate Headquarters** 3 Highwood West, Suite 100, Tewksbury, MA 01876 Tel. 781-395-7417 — 800-225-1633 (toll-free) — [sales.us@boston-group.com](mailto:sales.us@boston-group.com)

**European Headquarters** Sydneystraat 15, Rotterdam, 3047 BP, Netherlands Tel. +31 10 238 14 00 — [sales.emea@boston-group.com](mailto:sales.emea@boston-group.com) • [www.boston-group.com](http://www.boston-group.com) •

MADE IN THE USA • V SEPT 2025

# ECOSUPERFLEX<sup>®</sup>

1" radius, 80% recycled, flexible ecoSeries<sup>®</sup>

- Profile & base combined contain a minimum of 80% recycled content.
- Recycled content claim validated by UL Environment.
- A virgin cosmetic skin for optimum aesthetics and color flexibility.
- Engineered to easily radius curved or round surfaces.
- 100% recyclable, sustainable material.
- Continuous rolls of bumper cover eliminate scrap and reduce storage space requirements.
- UL-94 V-0 Fire Rating.
- Simple installation with a pre-slotted base channel.
- Highest impact resistance.
- Vast color options.

## Super Benefits

- Value engineered for 1" radius applications.
- 75% larger anti-compression strip minimizes compression caused by impact or extreme temperature changes.
- The bumper installs to the base channel by hand: no tools required.
- Connection is confirmed by a simple 'click' sound from the strong, clasp-lock closure system.

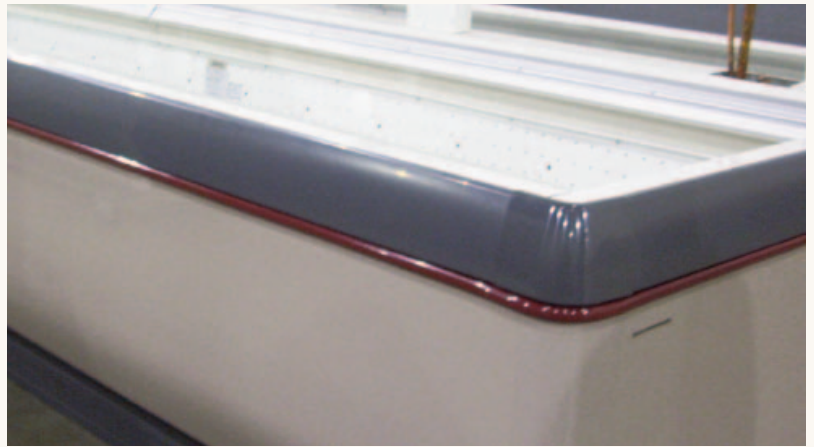

PROTECT

### Top



1" ecoSuperFlex Vinyl Top  
72' coils  
SFC1000-XXX\*

### Base

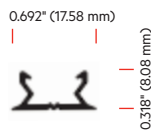

1" 100% Recycled Rigid Vinyl Base  
12' sections  
BRSF1000R

### End Cap

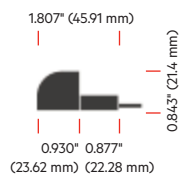

1" PolyBostylene<sup>®</sup> Round End Cap  
144 pieces per box  
PBERSF1000-XXX

### Corner Cap

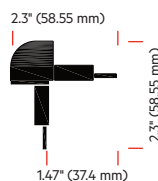

1" PolyBostylene<sup>®</sup> 90° End Cap  
PBCNSF1000-XXX

XXX Denotes that a color tab must be added to the part number at the end of the time of ordering. Custom and standard colors require minimum lead time and quantities. See separate color chart for color options.



POWER



PROTECT



FIXTURE



Boston Group

**Corporate Headquarters** 3 Highwood West, Suite 100, Tewksbury, MA 01876 Tel. 781-395-7417 — 800-225-1633 (toll-free) — sales.us@boston-group.com

**European Headquarters** Sydneystraat 15, Rotterdam, 3047 BP, Netherlands Tel. +31 10 238 14 00 — sales.emea@boston-group.com. [www.boston-group.com](http://www.boston-group.com)

# ECORIGID®

100% PVC-FREE Bumper, Base, Ends and Corner

The ecoRigid® bumper system is manufactured from 100% PVC-free PolyBostylene®. Engineered for flat surface applications, the ecoRigid® system provides a high level of impact resistance for your walls, fixtures and corners.



## Applying ingenuity around the world.

Boston Group provides total solutions to energize environments, protect assets and support unique shopping or working experience. We listen carefully, look beyond the challenge and come up with smart solutions, exploring new domains every day together with you. From initial concept to full product rollout we expertly guide the process to deliver the right solutions for your needs.



PROTECT



POWER



PROTECT



FIXTURE



Boston Group









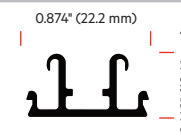
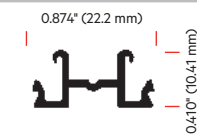

**Corporate Headquarters** 3 Highwood West, Suite 100, Tewksbury, MA 01876 Tel. 781-395-7417 — 800-225-1633 (toll-free) — [sales.us@boston-group.com](mailto:sales.us@boston-group.com)

**European Headquarters** Sydneystraat 15, Rotterdam, 3047 BP, Netherlands Tel. +31 10 238 14 00 — [sales.emea@boston-group.com](mailto:sales.emea@boston-group.com) [www.boston-group.com](http://www.boston-group.com)

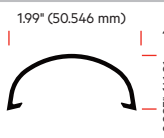
MADE IN THE USA • V SEPT 2025

# ECORIGID®

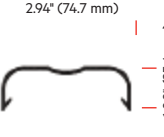
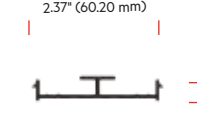
100% PVC-FREE Bumper, Base, Ends and Corners

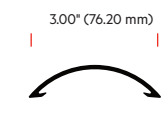
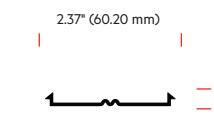
	Top	Base	Base
 <p><b>EcoRigid® 1000</b></p>	 <p>1.110" (28.19 mm) 0.843" (21.41 mm)</p>	 <p>0.874" (22.2 mm) 0.410" (10.41 mm)</p>	 <p>0.874" (22.2 mm) 0.410" (10.41 mm)</p>
 <p><b>EcoRigid® 2000</b></p>	 <p>1.99" (50.546 mm) 0.995" (41.91 mm)</p>	 <p>1.65" (41.91 mm) 0.370" (9.40 mm)</p>	 <p>1.65" (41.91 mm) 0.370" (9.40 mm)</p>
 <p><b>EcoRigid® 3000</b></p>	 <p>2.94" (74.7 mm) 1.00" (25.4 mm)</p>		 <p>2.37" (60.20 mm) .465" (11.8 mm)</p>
 <p><b>EcoRigid® 3050</b></p>	 <p>3.00" (76.20 mm) 0.750" (19.05 mm)</p>	 <p>2.37" (60.20 mm) .25" (6.35 mm)</p>	



POWER



PROTECT



FIXTURE

XXX Denotes that a color tab must be added to the part number at the end of the time of ordering. Custom and standard colors require minimum lead time and quantities. See separate color chart for color options.

Some colors available in virgin material only. Check with our customer service.

**End Cap**

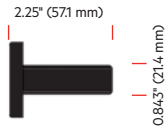

1" Flat  
PolyBostylene® End Cap  
144 pieces per box  
PBEF1000-XXX

**End Cap**

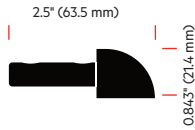

1" Round  
PolyBostylene® End Cap  
288 pieces per box  
PBER1000-XXX

**Corner Cap**

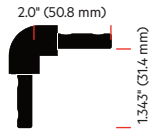

1" 90°  
PolyBostylene® Corner Cap  
144 pieces per box  
PBCN1000-XXX

**Corner Cap**



1" 135°  
PolyBostylene® Corner Cap  
144 pieces per box  
PBCX1000-XXX

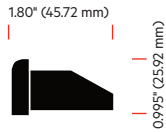

2" Flat  
PolyBostylene® End Cap  
144 pieces per box  
PBEF2000-XXX

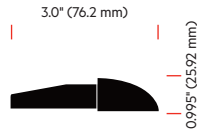

2" Round  
PolyBostylene® End Cap  
144 pieces per box  
PBER2000-XXX

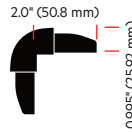

2" 90°  
PolyBostylene® Corner Cap  
144 pieces per box  
PBCN2000-XXX



2" 135°  
PolyBostylene® Corner Cap  
144 pieces per box  
PBCX2000-XXX

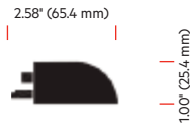

3" Round  
PolyBostylene® End Cap  
144 pieces per box  
PBER3000-XXX

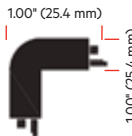

3" 90°  
PolyBostylene® Corner Cap  
144 pieces per box  
PBCN3000-XXX

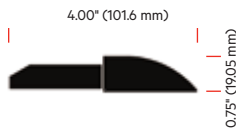

3" Round  
PolyBostylene® End Cap  
144 pieces per box  
PBCN3050-XXX

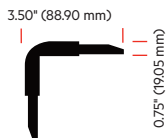

3" 90°  
PolyBostylene® Corner Cap  
144 pieces per box  
PBCN3050-XXX



# ECORIGID<sup>®</sup>

## 100% PVC-FREE Bumper, Base, Ends and Corner

- 100% pvc-free PolyBostylene<sup>®</sup> bumper, base, ends and corners (aluminum base option available).
- Engineered for flat surface applications.
- A 100% recyclable, sustainable material.
- RoHS Compliant.
- Free of Chlorine and Bromine hazardous chemicals.
- Compatible with all ecoFlex<sup>®</sup> and traditional Boston Bumper<sup>®</sup> parts.
- Does not cost a premium. Costs 15% less than traditional Boston Bumper<sup>®</sup>.
- Weighs 1/4 less than traditional rigid bumper, saving on freight costs.
- All PolyBostylene<sup>®</sup> base channels contributes towards LEED Materials & Resources: credit 5.1 & 5.2, Manufactured Regionally.
- UL-94HB Fire Rating.
- Simple installation with a pre-slotted base channel.
- High impact resistance.
- Vast color options.



PROTECT

**RoHS  
Compliant**



POWER



PROTECT



FIXTURE

Boston Group



**Corporate Headquarters** 3 Highwood West, Suite 100, Tewksbury, MA 01876 Tel. 781-395-7417 — 800-225-1633 (toll-free) — [sales.us@boston-group.com](mailto:sales.us@boston-group.com)

**European Headquarters** Sydneystraat 15, Rotterdam, 3047 BP, Netherlands Tel. +31 10 238 14 00 — [sales.emea@boston-group.com](mailto:sales.emea@boston-group.com) [www.boston-group.com](http://www.boston-group.com)

# EDGETRIM

Recyclable Flexible Display Trim

EdgeTrim is similar to T-Mold, as it installs easily, is cost-effective and provides tough impact protection for your fixtures and display cases. The difference is that Edge Trim is applied with double-sided tape, dual lock replaceable fasteners or adhesive cement. It's ideal for finishing off refrigeration end panels and table top circumferences.



## Applying ingenuity around the world.

Boston Group provides total solutions to energize environments, protect assets and support unique shopping or working experience. We listen carefully, look beyond the challenge and come up with smart solutions, exploring new domains every day together with you. From initial concept to full product rollout we expertly guide the process to deliver the right solutions for your needs.



PROTECT



POWER



PROTECT



FIXTURE

Boston Group

**Corporate Headquarters** 3 Highwood West, Suite 100, Tewksbury, MA 01876 Tel. 781-395-7417 — 800-225-1633 (toll-free) — [sales.us@boston-group.com](mailto:sales.us@boston-group.com)

**European Headquarters** Sydneystraat 15, Rotterdam, 3047 BP, Netherlands Tel. +31 10 238 14 00 — [sales.emea@boston-group.com](mailto:sales.emea@boston-group.com). [www.boston-group.com](http://www.boston-group.com)

# EDGETRIM

## Recyclable Flexible Display Trim

- Made with flexible compounds for high flexibility and pliability, so you can radius corners and curved or round surfaces with ease.
- Installs easily to protect the top and side of your counters and fixtures, while adding a decorative finishing edge.
- Ships in continuous rolls to eliminate scrap and reduce store space requirements.
- Sizes available to fit most makes and models of refrigeration cases.
- Custom lengths are available on request.
- Ships within 24 hours for stock black; an unlimited range of custom colors are available in a matte or gloss finish.



### PROTECT



Boston EdgeTrim,  
Gloss Finish,  
B=1.0"  
100' coil  
4 coils per box  
ETCG1.00-XXX

Boston EdgeTrim,  
Gloss Finish,  
B=1.25"  
100' coil  
4 coils per box  
ETCG1.250-XXX

Boston EdgeTrim,  
Gloss Finish,  
B=1.5"  
100' coil  
4 coils per box  
ETCG1.50-XXX

Boston EdgeTrim,  
Gloss Finish,  
B=1.75"  
100' coil  
4 coils per box  
ETCG1.75-XXX

Boston EdgeTrim,  
Gloss Finish,  
B=2.0"  
100' coil  
4 coils per box  
ETCG2.00-XXX



Boston EdgeTrim,  
Matt Finish,  
B=1.0"  
100' coil  
4 coils per box  
ETCM1.00-XXX

Boston EdgeTrim,  
Matt Finish,  
B=1.25"  
100' coil  
4 coils per box  
ETCM1.250-XXX

Boston EdgeTrim,  
Matt Finish,  
B=1.5"  
100' coil  
4 coils per box  
ETCM1.50-XXX

Boston EdgeTrim,  
Matt Finish,  
B=1.75"  
100' coil  
4 coils per box  
ETCM1.75-XXX

Boston EdgeTrim,  
Matt Finish,  
B=2.0"  
100' coil  
4 coils per box  
ETCM2.00-XXX



### POWER



### PROTECT



### FIXTURE

XXX Denotes that a color tab must be added to the part number at the end of the time of ordering. Custom and standard colors require minimum lead time and quantities. See separate color chart for color options.



Boston Group

**Corporate Headquarters** 3 Highwood West, Suite 100, Tewksbury, MA 01876 Tel. 781-395-7417 — 800-225-1633 (toll-free) — sales.us@boston-group.com

**European Headquarters** Sydneystraat 15, Rotterdam, 3047 BP, Netherlands Tel. +31 10 238 14 00 — sales.emea@boston-group.com. [www.boston-group.com](http://www.boston-group.com)

# Warehouse Protection

Protecting your warehouse/DC from damage

**Boston Group offers a wide array of impact protection. Protecting your warehouse/DC from damage – Hallways & Corridors, Receiving Shipping Areas, Storage Areas & More.**



**Applying ingenuity around the world.**

Boston Group provides total solutions to energize environments, protect assets and support unique shopping or working experience. We listen carefully, look beyond the challenge and come up with smart solutions, exploring new domains every day together with you. From initial concept to full product rollout we expertly guide the process to deliver the right solutions for your needs.



PROTECT



POWER



PROTECT



FIXTURE

**Boston Group**

**Corporate Headquarters** 3 Highwood West, Suite 100, Tewksbury, MA 01876 Tel. 781-395-7417 — 800-225-1633 (toll-free) — [sales.us@boston-group.com](mailto:sales.us@boston-group.com)

**European Headquarters** Sydneystraat 15, Rotterdam, 3047 BP, Netherlands Tel. +31 10 238 14 00 — [sales.emea@boston-group.com](mailto:sales.emea@boston-group.com) [www.boston-group.com](http://www.boston-group.com)

MADE IN THE USA • V SEPT 2025

# Warehouse Protection

Protecting your warehouse/DC from damage



## Bollards

Your facility takes a beating everyday from pallet jacks, fork lifts and cleaning equipment. Keep your equipment, walls and corners looking good by protecting them with the stainless steel Boston Bollard.



## Floor Mounted Corner Guards

Boston manufactures this complete line of 10-gauge, brush-finished stainless steel corner guards that can withstand impact up to 4,000 lbs! For your highest-traffic areas, they'll protect your corners from the daily assault of fork lifts and pallet jacks.



## Reflex Bollard

Our super heavy duty flexible bollard that protect capital assets by deflecting and stopping industrial mobile equipment from the damage they potentially cause. Available in 2 sizes. Will deflect and stop loads up to 22,000 lbs. of impact force.



## Box Rail

Box Rail 7 and Box Rail 48 provide extreme protection. Our complete range of Box Rail products are made of all steel components that protect against the daily punishment from fork trucks, hand trucks and equipment movers.



## Dock Door Protectors

Are fork lifts damaging the loading dock doors? Our dock door protectors safeguard both the door panels when in the down position as well as the door tracks in the up position.



## Vinyl Bollard Covers

Made of heavy duty Polyethylene plastic our Bollard covers are available in a variety of sizes.



## Warehouse Rack Guards

Protect your racking with our rack guards. Made with 12-gauge steel. These guards help reduce costly damage and keep your racking uprights intact.



PROTECT



POWER



PROTECT



FIXTURE

Boston Group



Energize your store

# Power

Simply energize your store with our plug-and-play systems. Our lighting products and modular power systems are easy to use, aesthetic and safe.



# Ingenuity applied means turning your problem into a solution

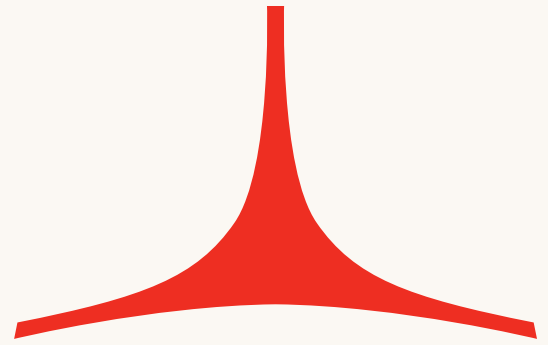

## Power applied at a Home Furnishings Store

Overhead power-grid flexible design & delivered on-time

Our client is a home furnishing retail store in the Middle East and India with over 85 stores in countries like Saudi Arabia, Bahrein, Qatar and Oman. Being in the business of making homes beautiful the stores themselves need to look elegant as well, including the ceilings.

**This Home Furnishings Store wanted** a new powered-grid solution that could support their merchandising and operational needs. The design needed to be flexible combining mechanical and electrical features that would be compliant with regional norms, all as soon as possible.

**First, we studied** their environment to understand their model, their needs and the way they wanted to use the overhead grid. By doing so, we were able to make a rather complex problem easy and developed a simple solution.

**We then proposed** several design options. Once the design was chosen, we bundled all elements and components, achieved regional compliance and tested before shipping. All of this was done within 3 months.

**The result?** We provided a solution that achieved their aesthetic and operational needs and delivered it on-time. The new overhead-powergrid solution offers a complete system maximizing efficiency, safety and speed. We even saved 4 weeks during the whole production cycle.

Now that's ingenuity applied.

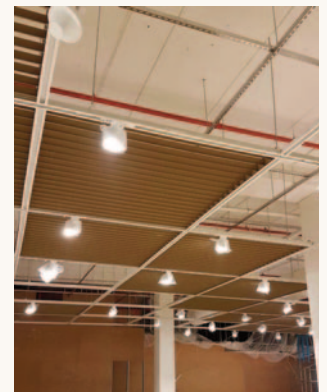

# Power solutions for any environment

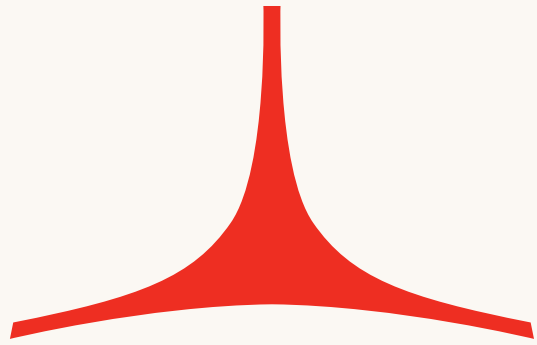

Simply energize your store or any commercial environment with our plug-and-play systems. Our lighting products and modular power systems are easy to use, aesthetic and safe. From creating your specific electrical plan to installation of our manufactured products, we can provide significant efficiency with your power needs.

The wide range of power distribution components allows you to connect all products from Boston Group in the easiest and most cost-effective way. All components are certified and can be connected and disconnected even under load.

## FASTLANE® Total Store 'Plug&Play' System

Boston's FastLane® modular wiring solutions are cost-effective 'Plug & Play' wiring methods that carry power and voice/data from electrical and computer patch panels to your selling floor.

Our Fastlane® wiring solutions are custom designed and configured to meet your specific needs while still allowing for a 100% functional, pre-tested modular installation. The system arrives 'as-designed' to eliminate hard wiring and 'on-the-fly design' common with traditional methods. Save installation time and labor costs with quick, reliable connections from the switch gear to point-of-use. Our total end to end solution of product and service provides power to all areas of a store: lighting/refrigeration/POS/Service areas. Currently installed in thousands of retail locations across US, Canada and Mexico.

## PowerPoles™

Boston Group offers a wide range of PowerPole product solutions that fulfill any power/voice and data distribution needs with UL compliant, reliable 'plug & play' connectors.

## PowerTrack™

Boston PowerTrack™ offers a simple solution for displaying powered fixtures. With a variety of channel lengths and receptacle spacing options, Boston PowerTrack™ can easily be configured to meet your specific display needs. Boston PowerTrack™ is the core electrical element of all Boston Wall, Rack & Gondola Mounted Lighting Displays, Clouds, and more.

## VersaPanel®

Boston's VersaPanel® is a versatile merchandising system that powers and displays lighting fixtures. Available in a variety of powder coated finishes, supporting power access every 1.97"/ 5 cm vertically. Standard and custom spacings available horizontally.

- Merchandise more in less space. Higher density displays leave more room for merchandise and graphic communications.
- Create a unique selling environment. Free-standing, suspended, wall, pallet racking & gondola platform options.
- Wide range of standard accessories with unlimited possibilities. Integrate duplex outlets, shelving, hooks, graphics and more to display product in their best light.

## Certification & Compliance

Every product we make adheres to strict third party national safety standards for mechanical, electrical and environmental compliance.



# It's all in the details

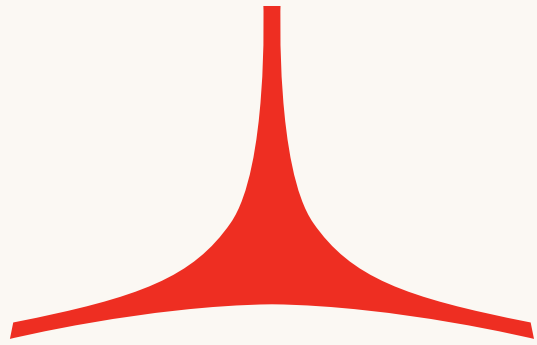

**Let our design, engineering and manufacturing experts help invigorate your environment**

Boston Group, founded in 1937, offers the very latest in design and manufacturing to turn your projects around quickly from concept to finished solutions.

## Integrated Solutions Philosophy

Boston Group designs and manufactures fixtures that bundle a variety of core materials (metal, wood, plastic, power, lighting and technology) into a modular design that allows seamless integration into any environment. Ingenuity Applied!

### Cutting edge capabilities

To stay competitive, Boston Group continuously invests in it's manufacturing capabilities to provide value driven solutions, quickly and efficiently.

### Insight and thoughtfulness

Our people make it all happen. To make a project viable, we formulate cross-functional teams comprising of account managers, designers, purchasers manufacturing engineers and customers service support.

### Experience with energy

The philosophy of Boston Group is to generate true value for our customers. We take time to understand your goals and objectives and apply our extensive experience to create configurable and scalable solutions for your environment.

## Challenge us...

At Boston Group, we love a good challenge. We strive to learn and push boundaries, so give us your toughest problem and we'll come up with a solution that meets your needs and budget.



# FastLane®

Total Store 'Plug&Play' System

Boston's FastLane® modular wiring products are cost-effective, 'Plug & Play', pre-terminated wiring solutions that distribute 20A power and CAT 5/6 telecommunications infrastructure wiring throughout your environment.



**Applying ingenuity around the world.**  
Boston Group provides total solutions to energize environments, protect assets and support unique shopping or working experience. We listen carefully, look beyond the challenge and come up with smart solutions, exploring new domains every day together with you. From initial concept to full product rollout we expertly guide the process to deliver the right solutions for your needs.



POWER



POWER



PROTECT



FIXTURE

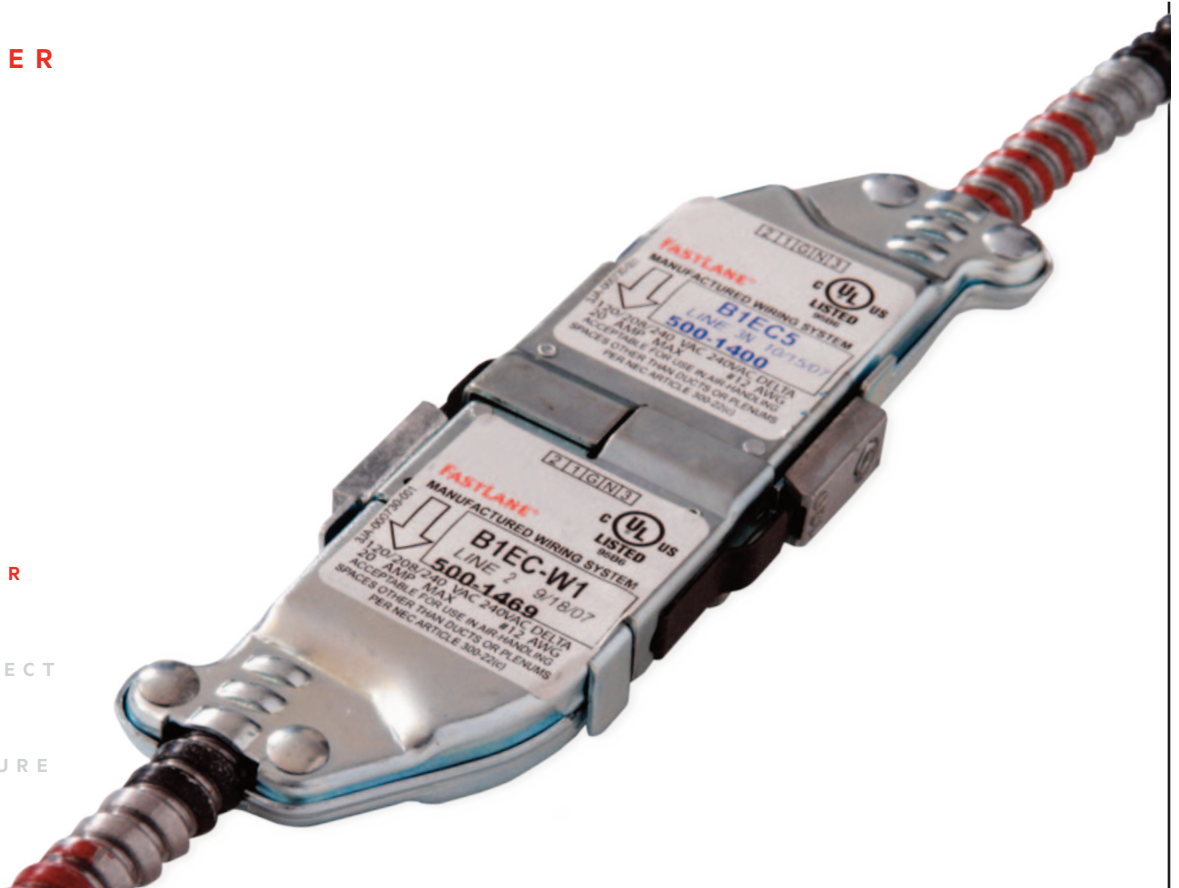

Boston Group

# FastLane®

## Total Store 'Plug&Play' System

FastLane® wiring products are designed and configured to meet your needs in a pre-tested, modular installation.

The product arrives kitted, labeled and pre-tested allowing for fast and simple assembly. Saves significant on-site labor costs and meets all codes and standards.

### The FastLane Advantage

- Shortens build and remodel cycles.
- Built-to spec and configured to your layout.
- UL listed and certified as components and as a system.
- Meets all National Electric codes (NEC) and requirements.



### Eco-Features Long-Term Benefits

- Reduces on site material waste.
- Contributes to LEED certification.
- The US Green Building Council (USGBC) Innovation in Design category highlights 'Plug and Play' Office' as earning LEED points (credit 1.1-1.4 Innovation in Design category).

### Long-Term Benefits

- Relocate & Reuse. System components can be disconnected and reused as needed.
- Built in future expandability.
- Longevity and reliability due to factory manufactured components.

### Technical Specifications

Built to specification, pre-wired & pre-tested modular components. Configured for complete 'plug & play' installation. Designed for use and certified with all Boston PowerPoles™, PlugStrips and Gondola PowerStrips.



POWER

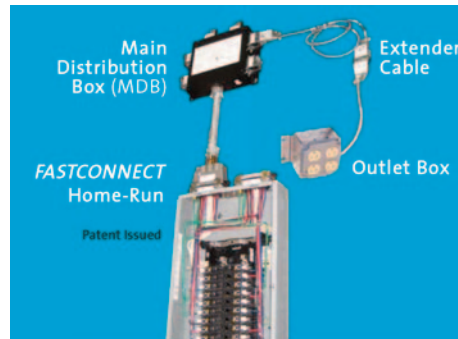

### Power Distribution

- General Purpose (GP) and Isolated Ground (IG) power circuits.
- UL listed and approved for 20A 120V branch power circuits.
- UL listed and approved for 20A 277V lighting power circuits.

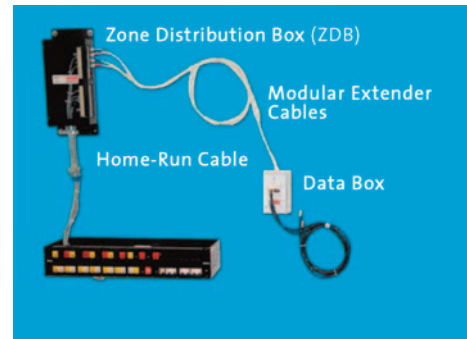

### Voice/Data Distribution

- Cat 5, 5E and 6 approved components.
- Vendor neutral components.
- Color coded and labeled per spec.



POWER



PROTECT



FIXTURE



### Safety & Reliability / UL and cUL Listed

Manufactured Wiring Systems: QQVX.E195520 (US) and QQVX7.E195520 (Canada).  
Multi-outlet Assemblies: PVGT.E195492 (US) and PVGT7.E195492 (Canada).  
Wiring Assemblies: QQYZ. E300763 (US).



Boston Group

**Corporate Headquarters** 3 Highwood West, Suite 100, Tewksbury, MA 01876 Tel. 781-395-7417 — 800-225-1633 (toll-free) — sales.us@boston-group.com

**European Headquarters** Sydneystraat 15, Rotterdam, 3047 BP, Netherlands Tel. +31 10 238 14 00 — sales.emea@boston-group.com. [www.boston-group.com](http://www.boston-group.com)

# PowerPoles™

Solving your connection problems.

Boston Group PowerPoles™ allows for power, telecommunications and other utilities to be run from overhead to floor level using our clean, organized certified extruded aluminum power poles. Powder-coated in any color to complement and match your needs. PowerPoles™ are built per spec and are easily assembled on site with a complement of connection hardware and bracketry.



## Applying ingenuity around the world.

Boston Group provides total solutions to energize environments, protect assets and support unique shopping or working experience. We listen carefully, look beyond the challenge and come up with smart solutions, exploring new domains every day together with you. From initial concept to full product rollout we expertly guide the process to deliver the right solutions for your needs.



POWER



POWER



PROTECT



FIXTURE

Boston Group

**Corporate Headquarters** 3 Highwood West, Suite 100, Tewksbury, MA 01876 Tel. 781-395-7417 — 800-225-1633 (toll-free) — [sales.us@boston-group.com](mailto:sales.us@boston-group.com)

**European Headquarters** Sydneystraat 15, Rotterdam, 3047 BP, Netherlands Tel. +31 10 238 14 00 — [sales.emea@boston-group.com](mailto:sales.emea@boston-group.com) [www.boston-group.com](http://www.boston-group.com)

MADE IN THE USA • V SEPT 2025

# PowerPoles™

Solving your connection problems.

Available as single or multi-channel poles that support running floor to ceiling utilities. PowerPoles™ are fully compatible for use with Boston Group's FastLane™ distributed wiring system.

- Product arrives packaged and labeled for easy identification in the field.
- Available powder coated in custom and standard colors.
- Made in the USA.
- Short lead times.
- UL listed and certified.
- Certified for use with Boston Group's FastLane™.
- Available with pre-wired receptacles and switches.

## Technical Specifications

- Structural aluminum extruded profile with secure fit connection between channels.
- Available in lengths from 2'-15' long single or multi-channel configurations.
- UL & cUL listed.
- NEC certified for use a power channel.



POWER

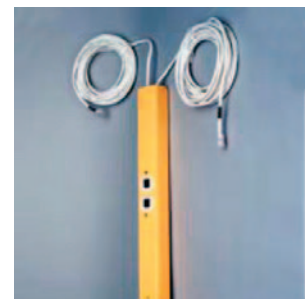

POWER



PROTECT



FIXTURE

The PowerTower™ power cluster can be used in conjunction with Boston PowerPoles™ to distribute power to a large number of displayed electric or electronic products.

Configurable for many electrical requirements including Boston Retail's FastLane™ branch power system.

Configurable for many communications requirements including Boston Retail's FastLane™ data wiring system.



Boston Group

# PowerTrack™

Modular, Custom-made, Certified

Boston PowerTrack™ offers a simple certified and approved solution for displaying powered and non-powered lighting fixtures. Built using channel lengths from 2'-12' and with standard receptacle spacing of 12" or 18" on center, Boston PowerTrack™ can easily be configured to meet your specific display needs. Available in 120V and 230V.



## Applying ingenuity around the world.

Boston Group provides total solutions to energize environments, protect assets and support unique shopping or working experience. We listen carefully, look beyond the challenge and come up with smart solutions, exploring new domains every day together with you. From initial concept to full product rollout we expertly guide the process to deliver the right solutions for your needs.



POWER

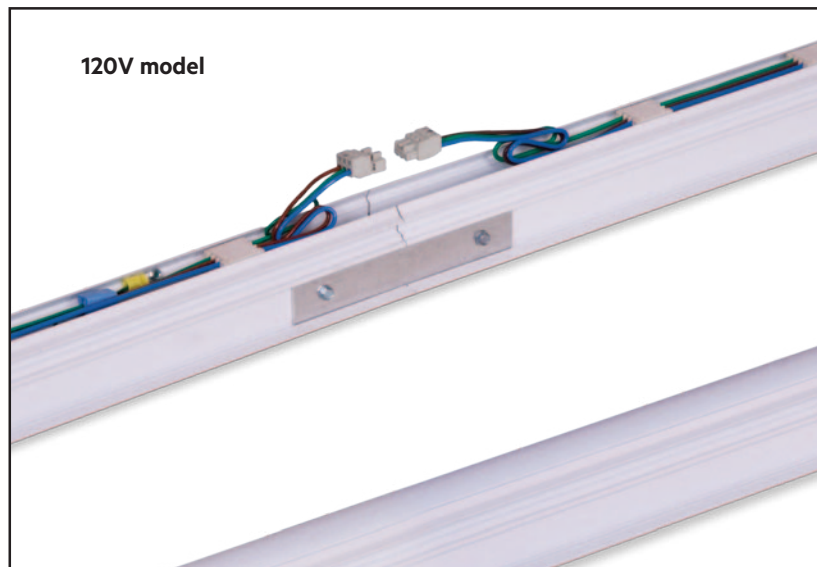

120V model



POWER



PROTECT



FIXTURE

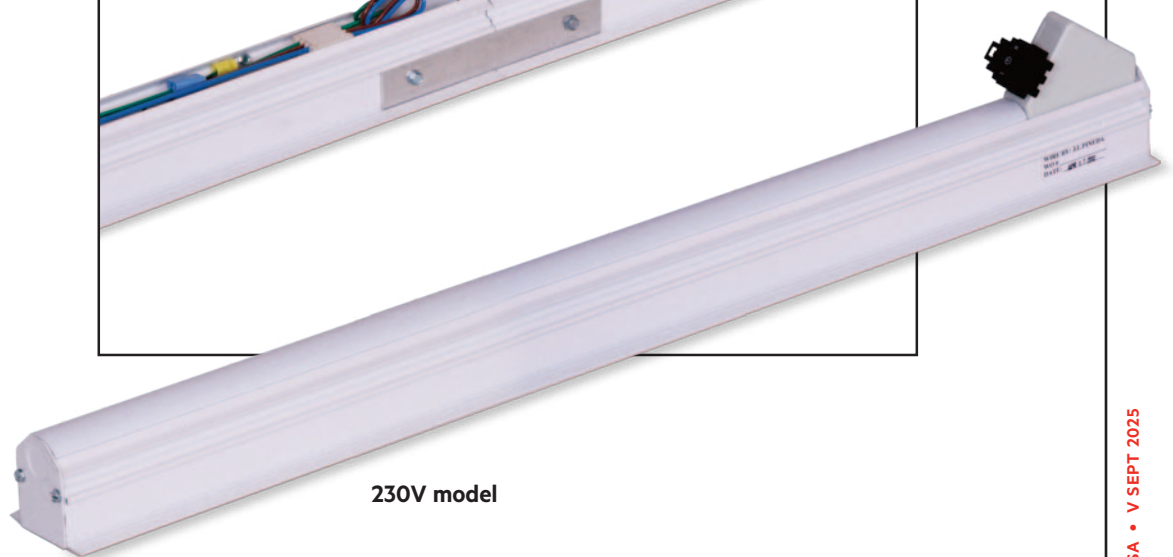

230V model

Boston Group

**Corporate Headquarters** 3 Highwood West, Suite 100, Tewksbury, MA 01876 Tel. 781-395-7417 — 800-225-1633 (toll-free) — [sales.us@boston-group.com](mailto:sales.us@boston-group.com)

**European Headquarters** Sydneystraat 15, Rotterdam, 3047 BP, Netherlands Tel. +31 10 238 14 00 — [sales.emea@boston-group.com](mailto:sales.emea@boston-group.com) • [www.boston-group.com](http://www.boston-group.com) •

MADE IN THE USA • V SEPT 2025

# PowerTrack™

Modular, Custom-made, Certified

A strong and sturdy extruded aluminum profile combined with preassembled power wiring and components, Boston PowerTrack™ is a versatile product that meets your display needs. Combined with variety of accessories, PowerTrack™ reduces installation time and cost with a certified safe reliable solution. Boston PowerTrack™ is the core electrical element of all Boston Wall, Rack & Gondola Mounted Lighting Displays, Clouds, and more.

- 12" or 18" on center (30 cm and 45 cm) receptacle spacing for maximum merchandising density.
- Pre-tested, certified and ready to install with easy-to-follow installation instructions.
- UL and cUL listed assemblies made to high quality standards.
- 120V, 20A and 230V, 50hz, 16A rated assemblies.
- Display lights and fans up to 50 lbs (22.5 kg) each with a maximum of 100 lbs (45 kg) distributed over 6' (1.8 m).
- Larger light fixtures can be supported directly from a structural ceiling with a custom Boston design.
- PowerTrack™ can hang from ceilings, Gondola uprights and Racking.



POWER



POWER



PROTECT



FIXTURE



Boston Group

**Corporate Headquarters** 3 Highwood West, Suite 100, Tewksbury, MA 01876 Tel. 781-395-7417 — 800-225-1633 (toll-free) — sales.us@boston-group.com

**European Headquarters** Sydneystraat 15, Rotterdam, 3047 BP, Netherlands Tel. +31 10 238 14 00 — sales.emea@boston-group.com. [www.boston-group.com](http://www.boston-group.com)



FIXTURE



PROTECT



POWER

**Boston Group**



**Corporate Headquarters** 3 Highwood West, Suite 100, Tewksbury, MA 01876 Tel. 781-395-7417 — 800-225-1633 (toll-free) — [sales.us@boston-group.com](mailto:sales.us@boston-group.com)

**European Headquarters** Sydneystraat 15, Rotterdam, 3047 BP, Netherlands Tel. +31 10 238 14 00 — [sales.emea@boston-group.com](mailto:sales.emea@boston-group.com) [www.boston-group.com](http://www.boston-group.com)

MADE IN THE USA • V SEPT 2025